

MP 1, SQE-NE, SPA-NE, SP-NE

Submersible pumps environmental
50/60 Hz



Contents

General data

Performance range	3
Environmental concern	4
Product range and application	5

MP 1

Technical data	8
Material specification (pump)	9
Material specification (motor)	9
Accessories	11

SQE-NE

General data	13
Features and benefits	15
Examples of applications	18
Communication	26
Pump selection	31
Curve conditions	33
Material specification (pump)	39
Material specification (motor)	39
Material specification (cable)	39
Accessories	41
Order data	43

SPA-NE, SP-NE

General data	44
Features and benefits	47
Curve conditions	49
Performance curves and technical data	50
Material specification (pump)	58
Material specification (motor)	58
Accessories	59
Table of head losses	70
Order data	72

Pumped liquids

Resistance list	73
-----------------	----

Performance range

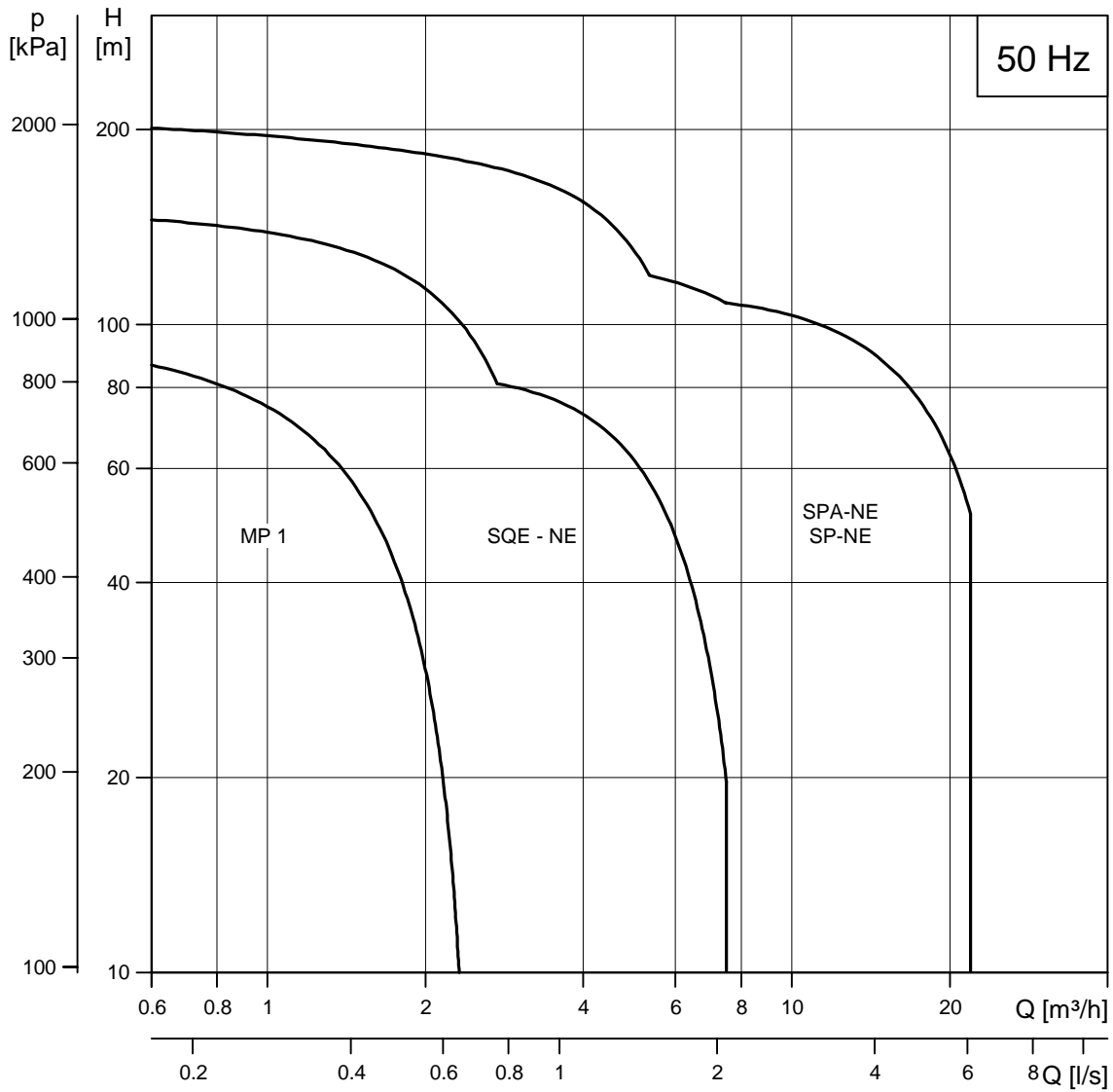

TM01 9132 0405

Environmental concern

Concern for the environment is growing.

Waste disposal and treatment is being put into a legal framework.

Investment in environmental protection is on the increase and many sectors are taking concrete steps to develop new solutions to environmental problems.

To that end, Grundfos offers a complete product range for applications ranging from sampling to pumping of polluted drainage water.

Sources of pollution

Pollution of the groundwater and, thus, potential contamination of the drinking water resources can be caused by one or more of the following conditions:

- Leaking pipes, storage tanks and sewage systems
- Spills and leaks from tank lorries or wagons
- Floods, landslides, etc.

In these cases, the potential damage to the environment can be minimized by pumping away the pollutants or the seepage water.

Industrial waste

Continuous and safe production in modern industry requires regulated disposal of waste. In the past, undesirable by products – such as residual materials or substances that could not be used, were often stored by companies on site. In the course of time, these materials and substances were often forgotten and some of them seeped into the ground.

Local authorities often have to deal with contaminated sites when the companies responsible for the contamination no longer exist or cannot afford the clean-up. Thanks to their high reliability and long life, Grundfos pumps offer a cost-effective solution.

Sampling

The new Grundfos pump range featuring heads up to 200 m and flow rates up to 22 m³/h are suitable for sampling of seepage water and groundwater. In addition to various geophysical methods, boreholes can be drilled to determine the chemical nature of seepage water and groundwater in order to determine how serious the contamination is. The Grundfos pumps are lowered into the borehole to pump up water for sampling. After the sampling, the pumps are pulled up again, cleansed and lowered into the next hole. Alternatively, the pumps are permanently installed in groundwater sampling wells for continuous duty.

Industrial wastewater treatment

Many industries produce highly polluted effluent. The large factories typically have their own treatment plants, the size and capacity of which match the big city plants.

Today not only industrial process water but also cooling and surface water go through chemical and physical purification in separate systems before being led into a water treatment plant and then discharged or recycled into production.

Pumps are an important link between contaminated and re-usable water. A number of environmental protection plants only exists thanks to the development of special environmental pumps, such as the cost-effective, maintenance-free and highly reliable Grundfos MP 1, SQE-NE, SPA-NE and SP-NE range, based on up-to-date material combinations.



TM02.0249 0405

Product range and application



TW019174 1300



CR9-407



TW019175 1300

Technical data	MP 1	SQE-NE	SPA-NE, SP-NE
Motor diameter	2"	3"	4"
Nominal flow rate [m ³ /h]	0.1 - 1	2 and 5	3 - 17
Max. head [m]	98	153	205
Motor power [kW]	1.3	0.6 - 1.7	0.75 - 5.5
Voltage supply [V]	1 x 220-240 V	1 x 200-240 V	1 x 220-230/240 V 3 x 200/220/380-415/500-525 V
Frequency [Hz]	50/60	50/60	50
Max. current [A]	5.5	11.2	13.0
Max. liquid temperature [°C]	35	40	40
Applications			
Sampling	•	•	•
Remedial pumping		•	•
Withdrawal of contaminated/polluted groundwater (from dumps, chemical depots etc.)		•	•
Pumping in water treatment systems	•	•	•
Pumping of industrial process water		•	•
Water quality monitoring	•	•	•
Mode of operation			
Continuous		•	•
Intermittent	•	•	•

For further information about suitable pump types see "Resistance list", page 73.

MP 1

MP 1 is an electrically driven 2" submersible pump for purging and sampling of contaminated/polluted groundwater.

The pump is driven via an adjustable BMI/MP 1 converter in the 50 to 400 Hz frequency range corresponding to a pump speed of max. 23,000 min⁻¹ and thus a nominal performance of 1 m³/h at 75 m head.

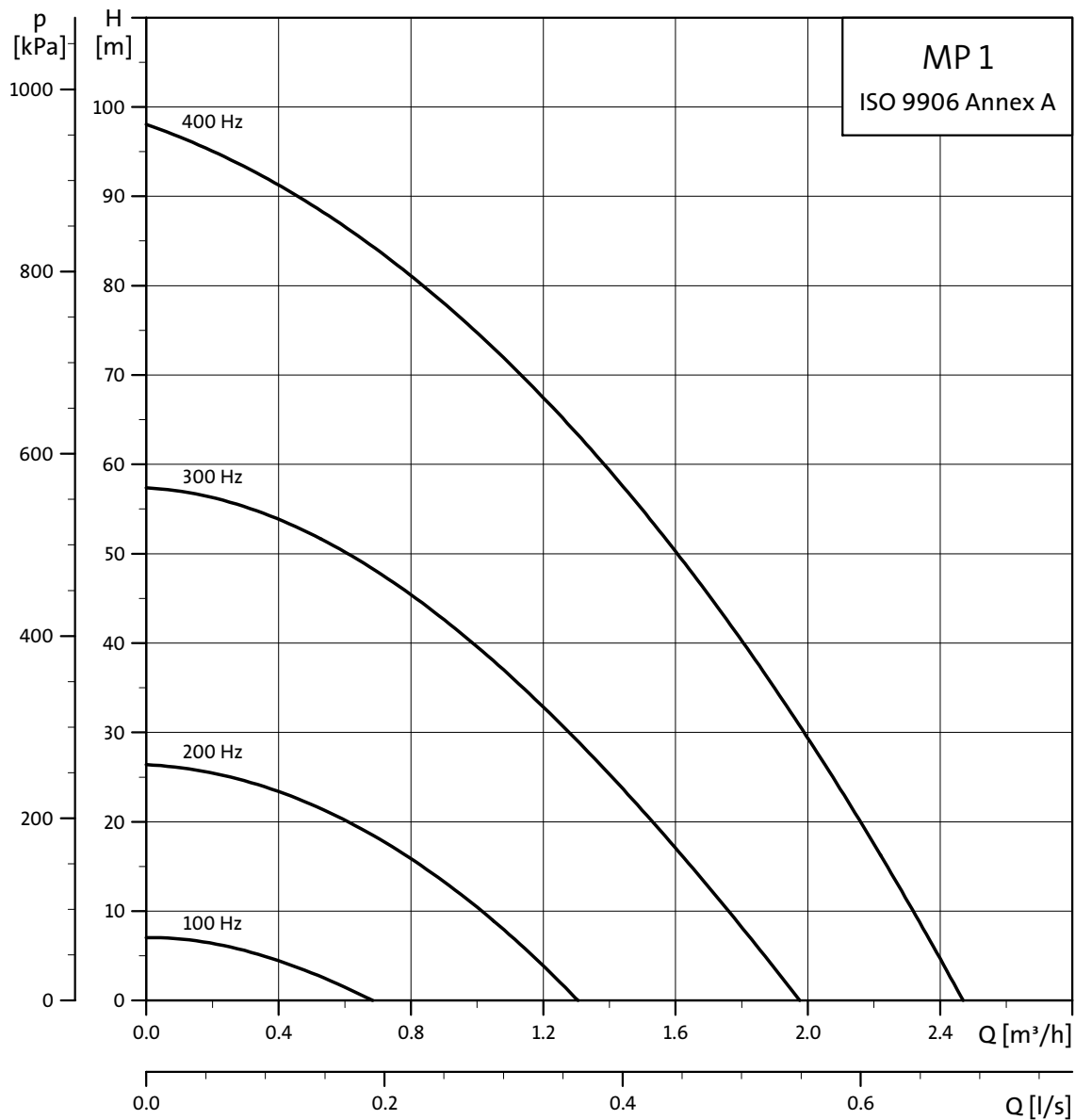

TM00 7778 2400

Applications

The MP 1 is designed for the pumping of contaminated/polluted groundwater for:

- Purging
- Sampling
- Water quality monitoring

The MP 1 has been specially developed for sampling, i.e. pumping of small quantities of water to be sent to the laboratory for analysis in order to establish:

- Content of contaminants.
- Concentration of contaminants.
- Extension of contamination plume.

The MP 1 pump is made of inert materials, which do not affect the pumped liquid and thus the analysis results.

The pump performance is adjusted by means of the converter which controls the pump speed via the frequency. In this way a steady, airfree water flow can be achieved.

The MP 1 offers efficient purging of the well before sampling as a high pump performance is achieved when the frequency is raised. Maximum performance is at 400 Hz.

However, the pump must not pump more water than the well can yield. Otherwise, the water table may fall to a level below the suction interconnector and air will be sucked into the pump. Besides reducing the cooling of the motor, this situation may damage the pump.

In order to avoid cleaning of the pump and possible cross-contamination, i.e. transfer of contaminants from one well to another, dedicated installation of the pump is recommended.

This also saves valuable time for the sampling technician as he can quickly disconnect the converter and proceed to the next MP 1 installation. The submersible drop cable is connected to the converter via a plug connection so that disconnection is possible without the use of tools.

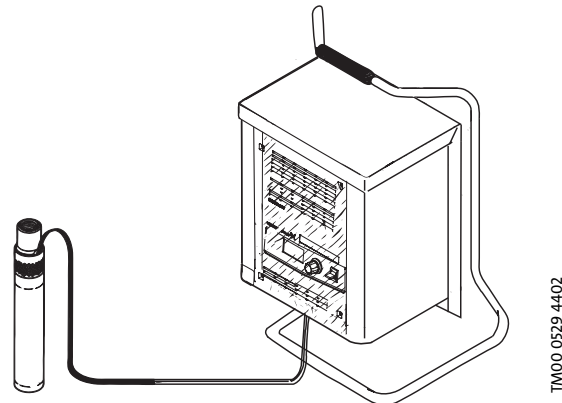

TM00 0529 4402

Type key

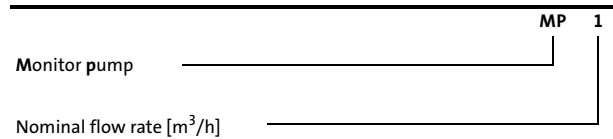

Pumped liquids

Contaminated/polluted groundwater, i.e. thin, non-explosive liquids without abrasive particles or fibres.

Liquid temperature: 0°C to +35°C during operation.

Maximum sand content: 50 g/m³.

A larger sand content will reduce the life of service parts considerably.

Note: The MP 1 pump is not built for the pumping of concentrated hydrocarbons, chemicals or explosive liquids. As the pump has not been approved as explosion-proof, local authorities and regulations should be consulted in case of doubt whether the MP 1 pump may be used.

If the density or the kinematic viscosity is higher than that of water, a higher input power than the nominal power will be required, and the maximum number of revolutions must therefore be reduced.

Overload protection

As the motor and converter have overload protection, the maximum output at which the overload protection does not switch off can be found through a trial-and-error procedure. Restart of the pump after switch-off requires resetting of the converter on the start/stop switch located on the front cover of the converter.

Product range

MP 1 is available in one size for connection to special converter and for Rp ¾ pipe connection. The pump is fitted with various motor cable lengths, according to the table below.

Motor cable length [m]	Product number MP 1, incl. cable, connecting thread Rp ¾
10	1A105103
20	1A105203
30	1A105303
40	1A105403
50	1A105503
60	1A105603
70	1A105703
80	1A105803
90	1A105903

MP 1 must be operated via a BMI/MP 1 converter custom-built to Grundfos specifications.

The converter is supplied without cable and plug for mains connection.

Designation	Product number
BMI/MP 1	1A9922

MP 1

Power consumption:	1.3 kW
Voltage:	3 x 220 V, 400 Hz
Current:	Max. 5.5 A
Pipe connection:	Rp ¾
Net weight (pump only):	2.5 kg.

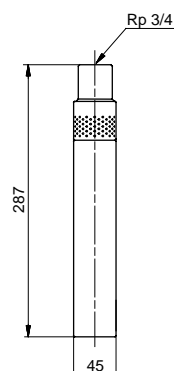

TM00 0531 0894

Converter BMI/MP 1

Supply voltage:	1 x 220-240 V -15%/+10%, 50/60 Hz, PE
Minimum generator size:	4.0 kVA
Maximum current:	10 A
Power factor:	0.65
Connecting cable:	3 x 1.5 mm ² 3 m with plug
Output voltage:	3 x 25 V, 50 Hz to 3 x 210 V, 400 Hz
Motor protection:	Built-in overcurrent protective device, set to 5.5 A
Acceleration time:	0 to 400 Hz: Max. 6 sec.
Deceleration time:	400 to 0 Hz: Max. 6 sec.
Enclosure class:	IP 21 (IP 23 when using converter stand with protection)
Ambient temperature during operation:	0°C to +40°C
Relative humidity:	Maximum 95%
Net weight:	3.7 kg

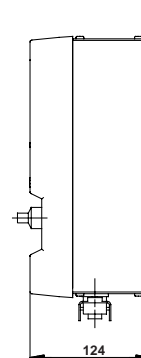
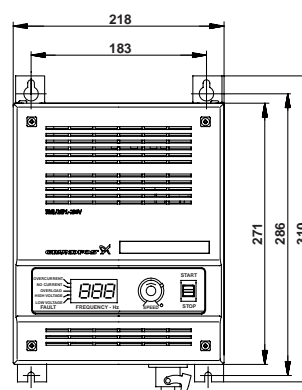

TM00 0532 4402

Service

Only pumps that can be certified as uncontaminated, ie pumps containing no hazardous and/or toxic material, may be returned to Grundfos for servicing.

To prevent injury to the health of persons involved and to the environment, a document certifying that the pump is clean is required.

Grundfos must receive this certificate before the product. Otherwise Grundfos will refuse to accept the product for servicing. Possible costs of returning the product are paid by the customer.

Converter stand

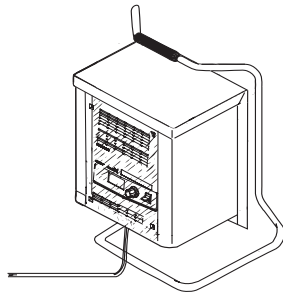

TM00 0892 4802

Description	Product no.
Facilitates handling of the converter and protects it against sprinkles and splashes of water.	1A5020
Enclosure class: IP 23.	

Straining wire

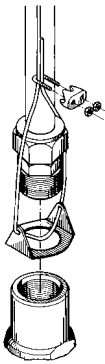

TM00 0875 4092

Description	Length [m]	Product no.
	10	1A5051
	20	1A5052
	30	1A5053
	40	1A5054
	50	1A5055
	60	1A5056
	70	1A5057
	80	1A5058
	90	1A5059
Separate wire lock.		1D5746

Wire holder for straining wire

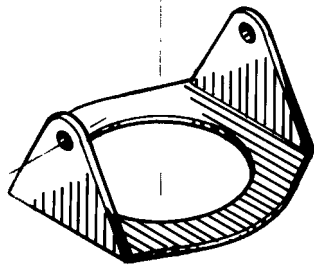

TM00 1277 4992

Description	Connecting thread	Product no.
The wire holder is fitted direct on top of the pump and fastened by means of riser pipe or hose union.	Rp ¼	1A0018
Material: Stainless steel DIN W.-Nr. 1.4401, AISI 316.		

Flexible hose

Description	Length [m]	Product no.
	10	1A0081
	20	1A0082
	30	1A0083
	40	1A0084
	50	1A0085
	60	1A0086
	70	1A0087
	80	1A0088
	90	1A0089

Diameter: 18/13 mm.
Material: PTFE transparent.
Pressure: Max. 10 bar.

Accessories

Coupling for flexible hose

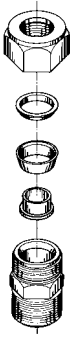

TM00 1278 4992

Description	Connecting thread	Product no.
The flexible hose is available with Rp ¼ compression coupling fitting.	Rp ¼	1A5030
Material: Stainless steel DIN W.-Nr. 1.4401, AISI 316.		

Flow sleeve



TM00 1286 4992

Description	Product no.
If the internal borehole diameter exceeds 80 mm, the pump can be fitted with a flow sleeve to ensure cooling of the motor.	
External diameter: 55 mm	1A108405
Total length: 310 mm	
Material: Stainless steel DIN W.-Nr. 1.4401, AISI 316.	

Performance range

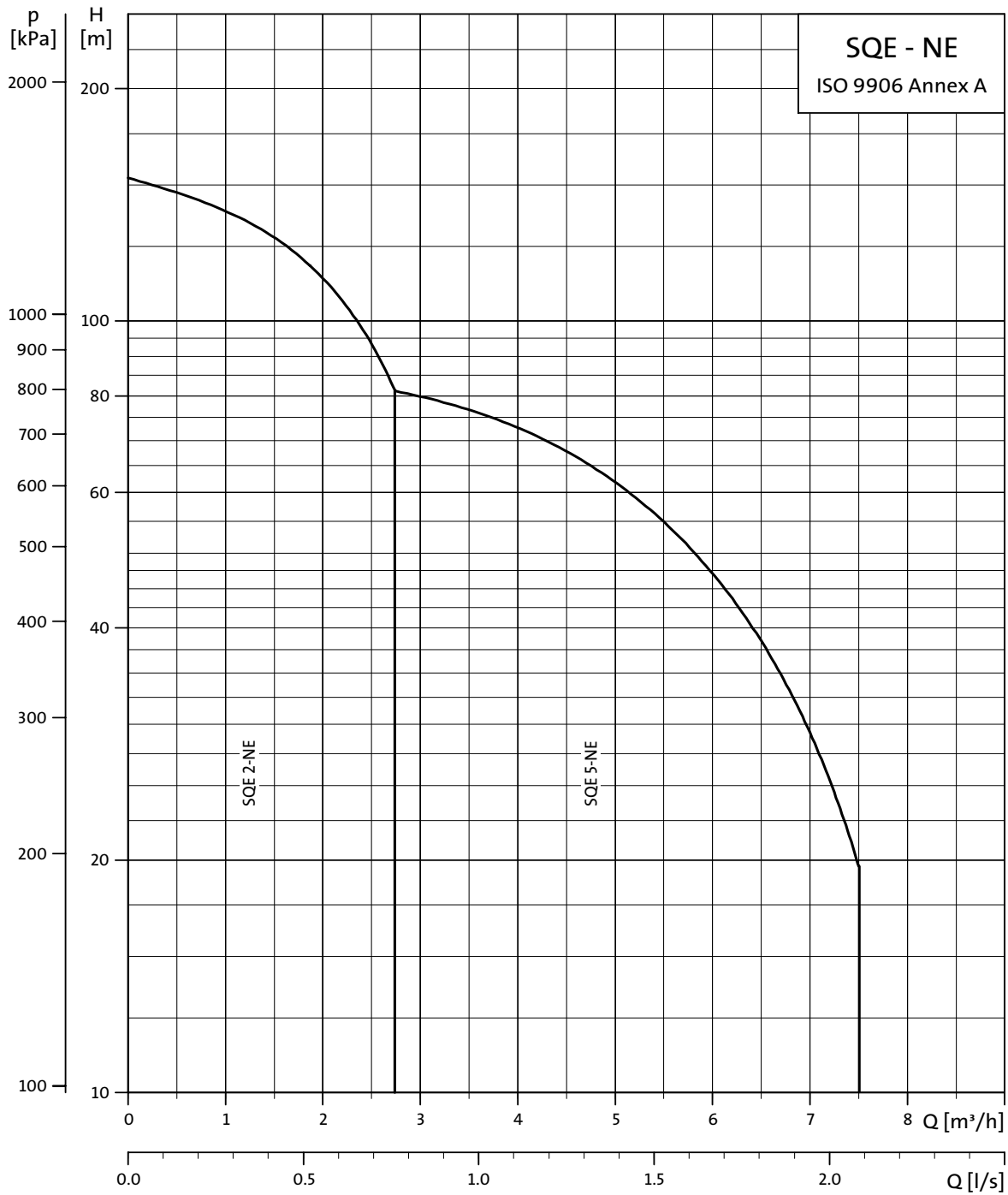

TM01 9343 3704

Applications

SQE-NE pumps are suitable for the following applications:

- Sampling
- Remedial pumping
- Withdrawal of contaminated water at
 - dumps
 - chemical depots
 - industrial sites
 - garages and filling stations
- Pumping in water treatment systems
- Pumping of industrial process water
- Water quality monitoring.

SQE-NE pumps are built for both continuous and intermittent operation.

Note: For other applications, please contact Grundfos.

Pump and motor

SQE-NE pumps offer the following features:

- dry-running protection,
- high efficiency of pump and motor,
- wear resistance,
- protection against upthrust,
- soft starting,
- overvoltage and undervoltage protection,
- overload protection,
- overtemperature protection,
- variable speed and
- electronic control and communication.

The submersible SQE-NE pump is fitted with a single-phase Grundfos MSE 3-NE motor, which is available in three sizes with a maximum power P_2 of 1.7 kW.

The MSE 3-NE permanent magnet motors are based on state-of-the-art technology, which is the main reason for their high efficiency. The integrated electronic unit of the motors comprises a frequency converter for soft starting.

The SQE-NE pump features variable speed which is offered through frequency control. Consequently the pump can be set to operate in any duty point in the range between the pump min. and max. performance curves.

The SQE-NE pump features communication with the Grundfos CU 300 control unit, which can be operated by means of the Grundfos R100 remote control.

The SQE-NE pump can also operate without the CU 300.

The CU 300 provide full control of the SQE-NE pump. In case of a pump fault, an alarm will be indicated on the front of the CU 300. The R100 enables monitoring of the installation and changing of the factory settings.

Pump and motor range

Product	Description	Material
SQE-NE pump	(2 and 5 m ³ /h)	Stainless steel DIN 1.4401 AISI 316
MSE 3-NE motor	Single-phase Max. 1.7 kW	Stainless steel DIN 1.4401 AISI 316

Pipe connection

Pump type	Threaded connection
SQE 2-NE	Rp 1½
SQE 5-NE	Rp 1½

Type key

Example	SQ	E	2	-50	NE
Type range	—	—	—	—	—
E = Electronic control and communication	—	—	—	—	—
Rated flow (in m ³ /h)	—	—	—	—	—
Head at rated flow (in m)	—	—	—	—	—
Material code:	—	—	—	—	—
N = Stainless steel DIN W.-Nr. 1.4401	—	—	—	—	—
E = Environmental. The pump is suitable for pumping of polluted liquids	—	—	—	—	—

Pumped liquids

The SQE-NE pump is suitable for use with slightly aggressive liquids such as contaminated groundwater and groundwater containing hydrogen carbonate.

SQE-NE pumps can pump liquids with a sand content of up to 50 g/m³. A higher content of sand will reduce pump life.

Operating range

Flow: 0.3-7.5 m³/h
Head: Max. 153 m.

Dry-running protection

The SQE-NE pumps are protected against dry running. A factory-set $P_{\text{cut-out}}$ value ensures cut-out of the pump in case of lack of water in the borehole thus preventing a burnout of the motor.

High pump efficiency

The hydraulic pump components are PVDF CN-F reinforced with 10% carbon fibre. The hydraulic design gives high pump efficiency meaning low energy consumption and therefore low energy costs.

High motor efficiency

The MSE 3-NE motor is based on a permanent magnet rotor (PM motor) featuring high efficiency within a wide load range.

The high, flat efficiency curve of the PM motor enables the same motor to cover a wide power range compared to conventional AC motors. For SQE-NE pumps, this means fewer motor variants.

Wear resistance

The SQE-NE pump design features impellers which are not fastened to the shaft ("floating"). Each impeller has its own tungsten carbide/ceramic bearing. The design and materials chosen ensure high wear resistance to sand for long product life.

Protection against upthrust

Starting up a pump with a very low counter pressure involves the risk of the entire impeller stack being lifted - also called upthrust. Upthrust may cause breakdown of both pump and motor. The MSE 3-NE is fitted with a top bearing protecting both pump and motor against upthrust and thus preventing breakdown during the critical start-up phase.

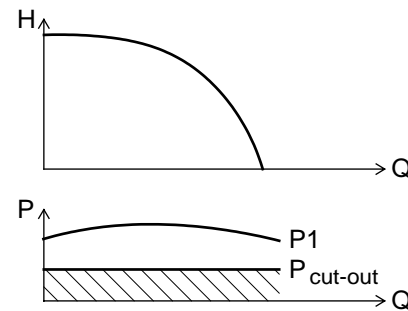

TM01 2751 2298

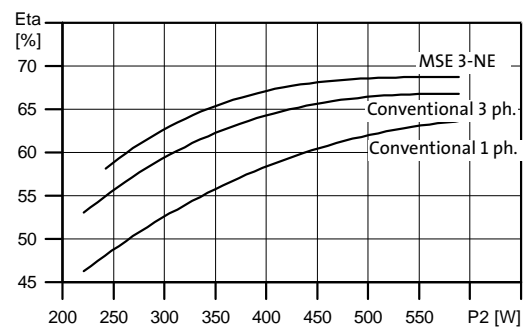

TM01 2698 2298



TM01 3141 3498

Excellent starting capabilities

The integrated electronic unit of the MSE 3-NE motors features soft starting. Soft start reduces the starting current and thus gives the pump a smooth and steady acceleration.

The soft starter minimizes the risk of pump wear and prevents overloading of the mains during start-up.

The excellent starting capabilities are a result of the high locked-rotor torque of the permanent magnet motor together with the few pump stages. The high starting reliability also applies in case of low voltage supply.

Overvoltage and undervoltage protection

Overvoltage and undervoltage may occur in case of unstable voltage supply.

The integrated protection of the MSE 3-NE motors protects the motor in case the voltage falls outside the permissible voltage range.

The pump will be cut out if voltage falls below 150 V or rises above 315 V. The motor is automatically cut in again when the voltage is again within the permissible voltage range. Therefore no extra protection relay is needed.

Overload protection

Exposure of the pump to heavy load causes the current consumption to rise. The motor will automatically compensate for this by reducing the speed to 3000 rpm. Further overload will lead to stop.

The same applies if the rotor is being prevented from rotating this will automatically be detected and the power supply cut out. Consequently, no extra motor protection is required.

Overtemperature protection

A permanent magnet motor gives off very little heat to its surroundings. In combination with an efficient internal circulation system providing cooling of the rotor, stator and bearings, this ensures optimum operating conditions for the motor.

As an extra protection, the electronic unit has a built-in temperature sensor. When the temperature rises too high, the motor is cut out. When the temperature has dropped, the motor is automatically cut in again.

Reliability

Designed with a view to high reliability the MSE 3-NE motors offer the following features:

- Tungsten carbide/ceramic bearings.
- Thrust bearings protecting against downthrust.
- Product life time equal to conventional AC motors.

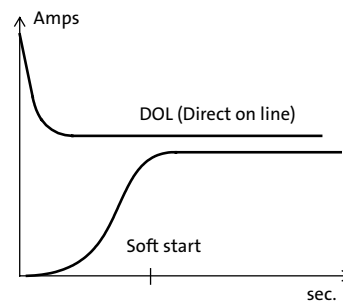

TM01 3479 4198

Variable speed

The MSE 3-NE motor enables continuously variable speed control within the 3000 and 10700 rpm. The pump can be set to operate in any duty point in the range between the 3000 and 10700 rpm performance curves of the pump. Consequently, the pump performance can be adapted to any specific requirement.

The variable speed control facility requires the use of the CU 300 or CU 301 control unit and the R100.

For the calculation of pump speed the PC tool "SQE speed calculation" is available on CD-ROM as an accessory, see page 42. On the basis of a required head and flow the speed of the motor is calculated. Furthermore, the specific pump performance curve can be illustrated.

Installation

The SQE-NE is suitable for vertical, as well as horizontal installation or any position inbetween.

Note: The pump must never be installed below the horizontal plane in relation to the motor.

The following features ensure simple installation of the SQE-NE pumps:

- Built-in non-return valve with spring.
- Low weight for user-friendly handling.
- Installation in 3" or larger boreholes.
- Only an on/off switch is required, meaning that there is no need for motor starter or starter box.
- A cable with plug is available on request (up to 80 m).

For horizontal installation a flow sleeve is recommended in order to

- ensure sufficient flow velocity past the motor and thus provide sufficient cooling and to
- prevent motor and electronic unit from being buried in sand or mud.

Service

The modular pump and motor design facilitates installation and service. The cable with plug is fitted to the pump with screws, which facilitates replacement.

Only pumps that can be certified as uncontaminated, ie pumps containing no hazardous and/or toxic material, may be returned to Grundfos for servicing.

To prevent injury to the health of persons involved and to the environment, a document certifying that the pump is clean is required.

Grundfos must receive this certificate before the product. Otherwise Grundfos will refuse to accept the product for servicing. Possible costs of returning the product are paid by the customer.

Example: SQE-NE

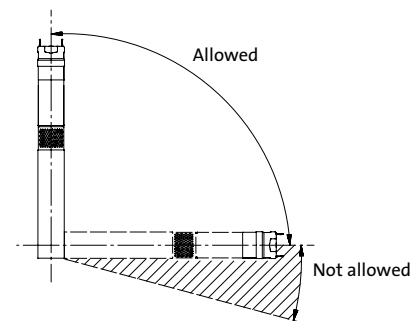

TM01.1375.1498

Sampling at variable speed

Function and benefits

The SQE-NE pump is ideally suited for the sampling of water as the pump materials are resistant to aqueous solutions of chemicals, oils, etc.

Prior to sampling, the well must be purged several times at high pump speed to make sure that the sample will be representative. Subsequently the sample must be taken at low pump speed in order not to affect the quality of the water and to avoid degassing.

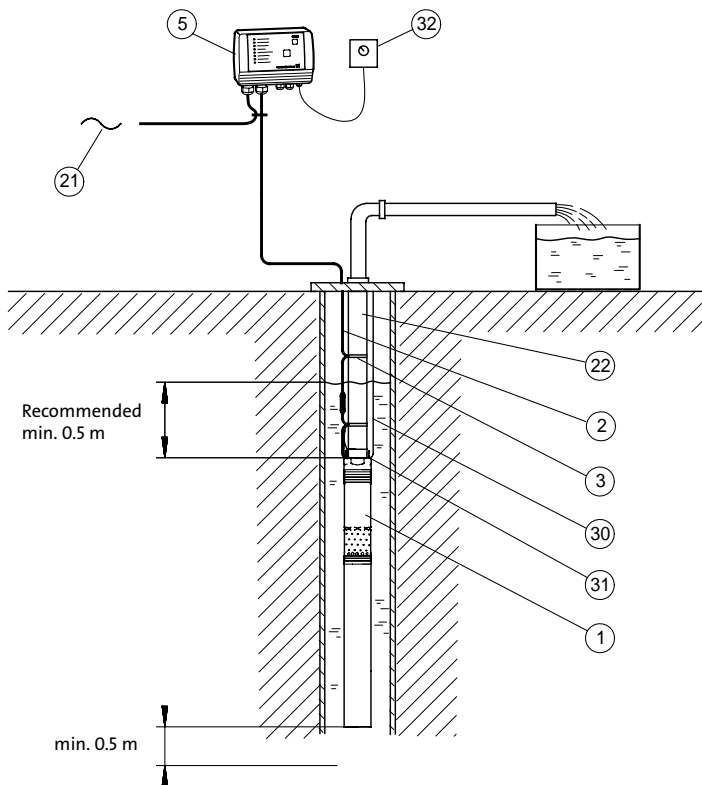

- 1 SQE-NE, pump
- 2 Cable
- 3 Cable clips
- 5 CU 300, control unit
- 21 Mains connection, 1 x 200-240 V, 50/60 Hz
- 22 Riser pipe
- 30 Stainless steel straining wire
- 31 Stainless steel wire clamp, 2 per lifting eye
- 32 SPP1, potentiometer

TM01 9028.1000

Sampling at variable speed

Pos.	Part	Type	No. of units	Product number	Unit price	Total price
1	SQE-NE, pump					
2	Cable					
3	Cable clips					
5	Control unit	CU 300				
22	Riser pipe					
30	Stainless steel straining wire					
31	Stainless steel wire clamp	2 per lifting eye				
32	SPP1, potentiometer					

Dewatering system

Function and benefits

The dewatering system is ideal in applications where the pump often runs dry, e.g. in boreholes with a low yield or in boreholes where the water table should be lowered, e.g. in a building site.

Air entering the pump together with water due to a drop in the water level causes the motor load and, consequently, the pump power input to decrease.

If the pump power input falls below a minimum power limit set via the R100, the pump stops.

The pump setting can be made in a workshop by means of a CU 300, and subsequently the pump can be installed in the borehole. If the setting is made in this way, it is not necessary to include the CU 300 in the application below.

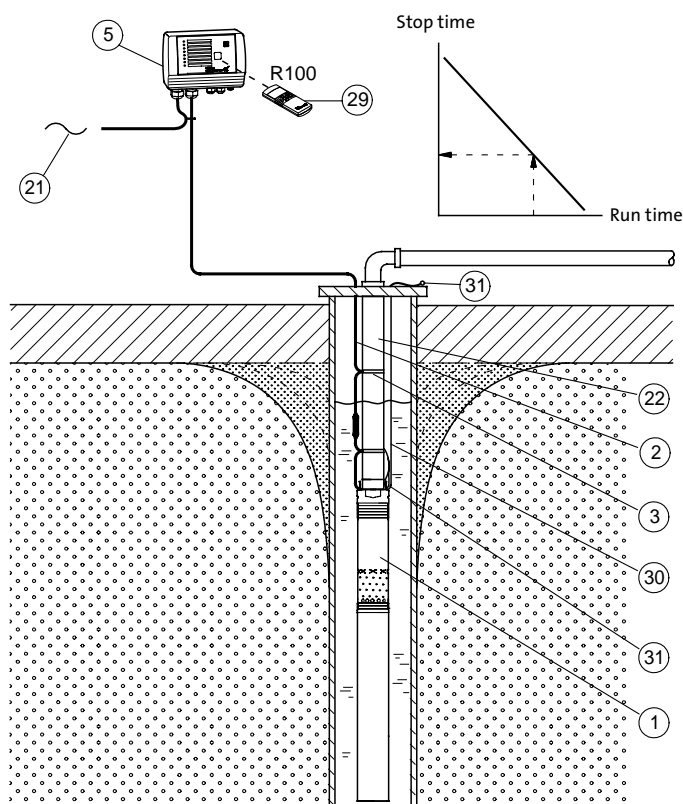

- 1 SQE-NE, pump
- 2 Cable
- 3 Cable clips
- 5 CU 300, control unit
- 21 Mains connection, 1 x 200-240 V, 50/60 Hz
- 22 Riser pipe
- 29 R100, remote control
- 30 Straining wire
- 31 Wire clamp

TM01 9412 1900

Dewatering system

Pos.	Part	Type	No. of units	Product number	Unit price	Total price
1	SQE-NE, pump					
2	Cable					
3	Cable clips					
5	Control unit	CU 300				
22	Riser pipe					
29	Remote control	R100				
30	Straining wire					
31	Wire clamp					

Maintaining a constant water table

Functioning and benefits

The water table can be maintained at a constant level by adjusting pump performance. For example, maintaining a constant water table is useful when the groundwater should be kept out of a building site or when salt water should be kept from penetrating a borehole containing potable water.

The example shows how to maintain a constant water table by adjusting pump performance. At low or no flow and thereby low performance, the flow meter ensures that the pump stops in order to avoid overheating of the motor.

Sensors:

Level	Description	Reaction
Level sensor (pos. 11)		
Warning (max.)	Too high water level. Possible cause: Insufficient pump capacity.	Alarm relay operates.
Desired level	The water level which should be maintained.	
Warning (min.)	Too low water level. Possible cause: Too high pump capacity.	Alarm relay operates.

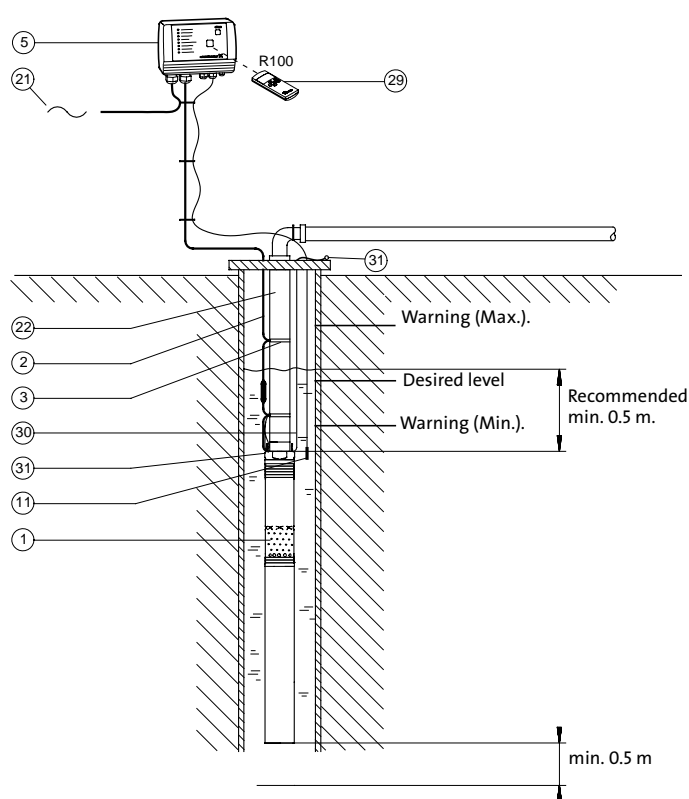

- 1 SQE-NE, pump
- 2 Cable
- 3 Cable clips
- 5 CU 300, control unit
- 11 Level sensor
- 21 Mains connection, 1 x 200-240 V, 50/60 Hz
- 22 Riser pipe
- 29 R100, remote control
- 30 Straining wire
- 31 Wire clamp

TM01.2459 4801

Maintaining a constant water table

Pos.	Part	Type	No. of units	Product number	Unit price	Total price
1	SQE-NE, pump					
2	Cable					
3	Cable clips					
5	Control unit	CU 300				
11	Level sensor					
22	Riser pipe					
29	Remote control	R100				
30	Straining wire					
31	Wire clamp					

Systems with three sensors connected

Function and benefits

The CU 300 enables systems with three sensors connected.

Sensors:

Level	Description	Reaction
pH sensor on ground (pos. 33)		
Warning	The pH-value is close to the maximum value allowed.	Alarm relay operates.
Alarm	The pH-value has reached the maximum value allowed.	The pump is stopped. The indicator light "sensor alarm" is lit.

Level	Description	Reaction
Level sensor in borehole (pos. 11)		
Warning (top)	Too high water level. Possible cause: Insufficient pump capacity.	Alarm relay operates.
Max. (start)	When the water has reached this level, the pump starts.	Green indicator light in on/off-button is constantly lit.
Min. (stop)	When the water has reached this level, the pump stops.	Green indicator light in on/off-button flashes.
Warning (bottom)	Too low water level in borehole. Possible cause: Pumping in adjacent boreholes.	Alarm relay operates.

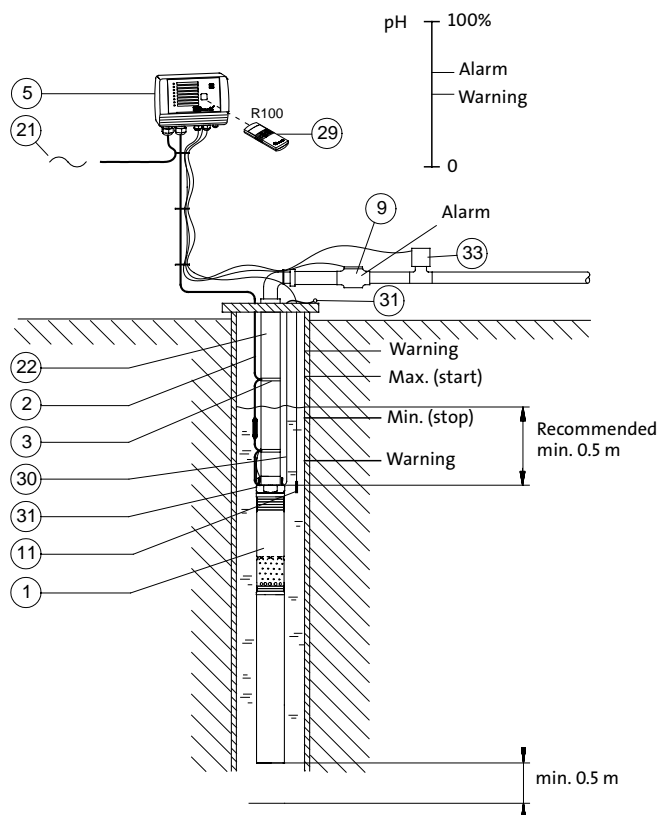

- 1 SQE-NE, pump
- 2 Cable
- 3 Cable clips
- 5 CU 300, control unit
- 9 Pulse flow meter
- 11 Level sensor
- 21 Mains connection, 1 x 200-240 V, 50/60 Hz
- 22 Riser pipe
- 29 R100, remote control
- 30 Straining wire
- 31 Wire clamp
- 33 pH sensor

TM01 9394-1800

Systems with three sensors connected

Pos.	Part	Type	No. of units	Product number	Unit price	Total price
1	SQE-NE, pump					
2	Cable					
3	Cable clips					
5	Control unit	CU 300				
9	Pulse flow meter					
11	Level sensor					
22	Riser pipe					
29	Remote control	R100				
30	Straining wire					
31	Wire clamp					
33	pH sensor					

Filling a tank from borehole using level control

Function and benefits

The SQE-NE pump with CU 300 is ideal for filling a tank from a borehole.

Level	Description	Reaction
Level sensor in tank (pos. 11)		
Warning (top)	Too high water level, e.g. due to rainwater in tank.	Alarm relay operates.
Max. (stop)	When the water has reached this level, the pump stops.	Green indicator light in on/off-button flashes.
Min. (start)	When the water has reached this level, the pump starts.	Green indicator light in on/off-button is constantly lit.
Warning (bottom)	Too low water level, e.g. due to a too small pump performance.	Alarm relay operates.
Level sensor in borehole (pos. 12)		
Alarm	Too low water level, e.g. due to a too small pump performance.	The pump stops. Alarm relay operates, and the indicator light "sensor alarm" is lit.

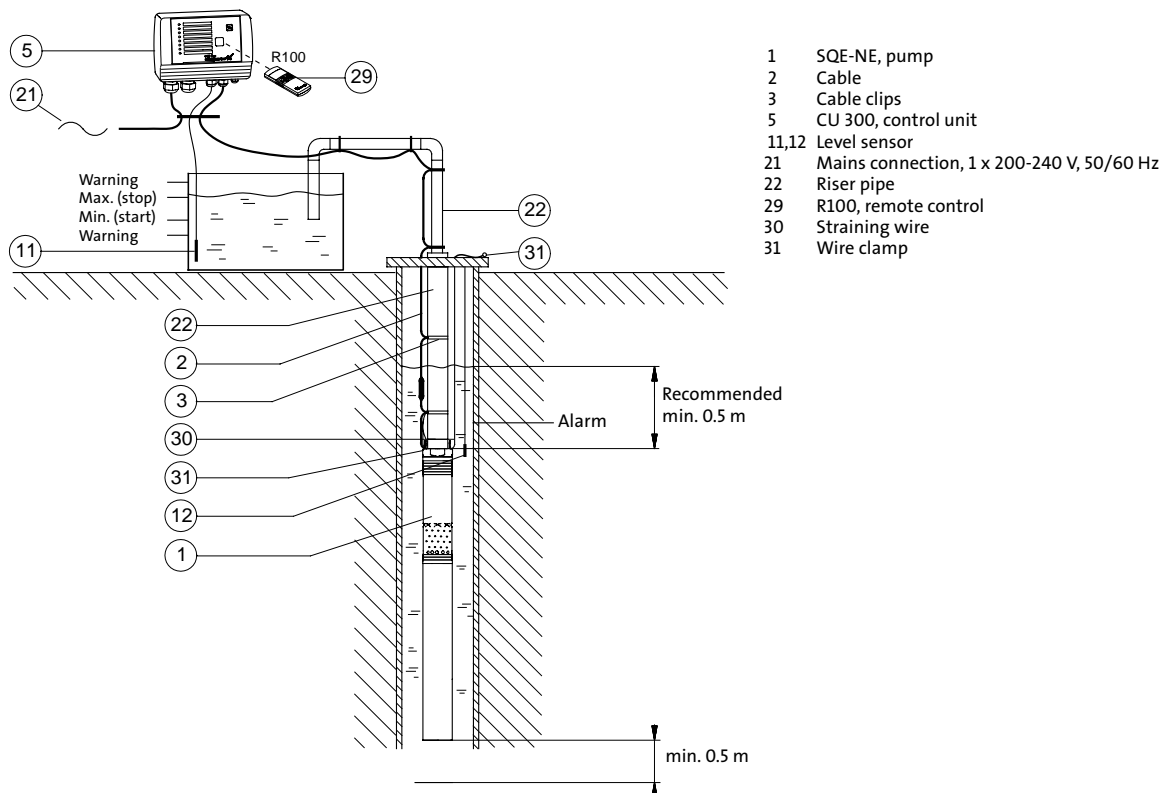

TM01 9395 1800

Filling a tank from borehole using level control

Pos.	Part	Type	No. of units	Product number	Unit price	Total price
1	SQE-NE, pump					
2	Cable					
3	Cable clips					
5	Control unit	CU 300				
11	Level sensor					
12	Level sensor					
22	Riser pipe					
29	Remote control	R100				
30	Straining wire					
31	Wire clamp					

Remedial pumping with water quality monitoring

Function and benefits

By means of sensor communication, it is possible to carry out remedial pumping of liquids such as water-soluble chemicals, oils, etc.

Remedial pumping is carried out, for example, in connection with the treatment of the groundwater surrounding a dump. The process can involve both recovery and treatment by separating the chemicals or oil from the recovered water. Subsequently the water is led back into the ground.

Level	Description	Reaction
Level sensor in borehole (pos. 11)		
Warning (top)	Too high water level in borehole. Possible cause: Insufficient pump capacity.	Alarm relay operates.
Max. (start)	When the water reaches this level, the pump starts.	Green indicator light in on/off-button is constantly lit.
Min. (stop)	When the water reaches this level, the pump stops.	Green indicator light in on/off-button flashes.
Warning (bottom)	Too low water level in borehole. Possible cause: Pumping in adjacent boreholes.	Alarm relay operates.
pH sensor on ground (pos. 33)		
Warning	The pH-value is close to the maximum value allowed.	Alarm relay operates.
Alarm	The pH-value has reached the maximum value allowed.	The pump stops. The indicator light "sensor alarm" is lit.

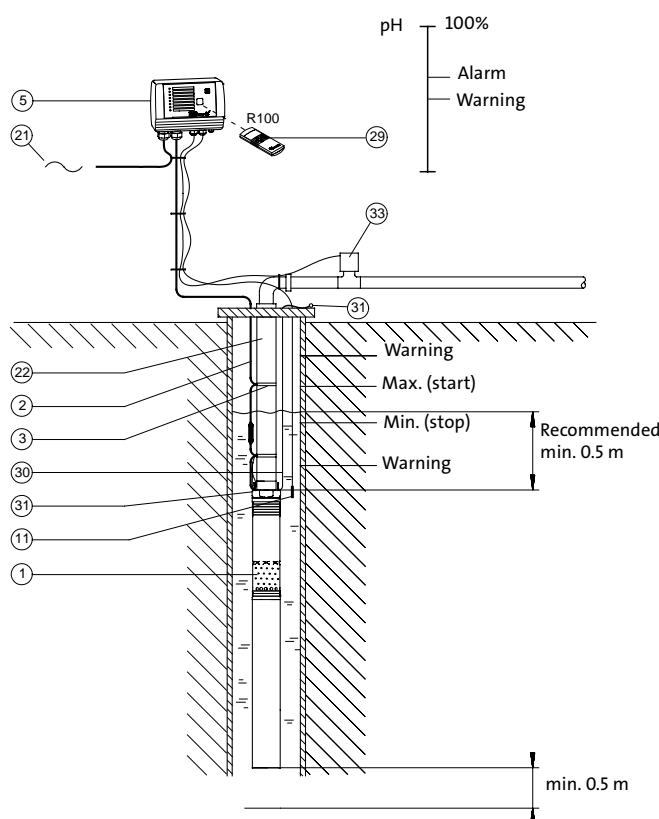

- 1 SQE-NE, pump
- 2 Cable
- 3 Cable clips
- 5 CU 300, control unit
- 11 Level sensor
- 21 Mains connection, 1 x 200-240 V, 50/60 Hz
- 22 Riser pipe
- 29 R100, remote control
- 30 Straining wire
- 31 Wire clamp
- 33 pH sensor

Remedial pumping with water quality monitoring

Pos.	Part	Type	No. of units	Product number	Unit price	Total price
1	SQE-NE, pump					
2	Cable					
3	Cable clips					
5	Control unit	CU 300				
11	Level sensor					
22	Riser pipe					
29	Remote control	R100				
30	Straining wire					
31	Wire clamp					
33	pH sensor					

TM01 9397 1800

Workshop setting of operating parameters

Using the R100 and the CU 300 enables change of the motor speed in a workshop and thereby setting of the pump to a specific performance.

A program called "SQE Speed Calculation" has been developed for the calculation of the speed in order to obtain the required flow rate and head.

Dry-running protection

The $P_{\text{cut-out}}$ value, ensuring dry-running protection, is factory-set for the SQE-NE pump.

If the speed of the SQE-NE pump is reduced by more than 1000 min^{-1} the $P_{\text{cut-out}}$ value must be readjusted by means of the CU 300 and R100.

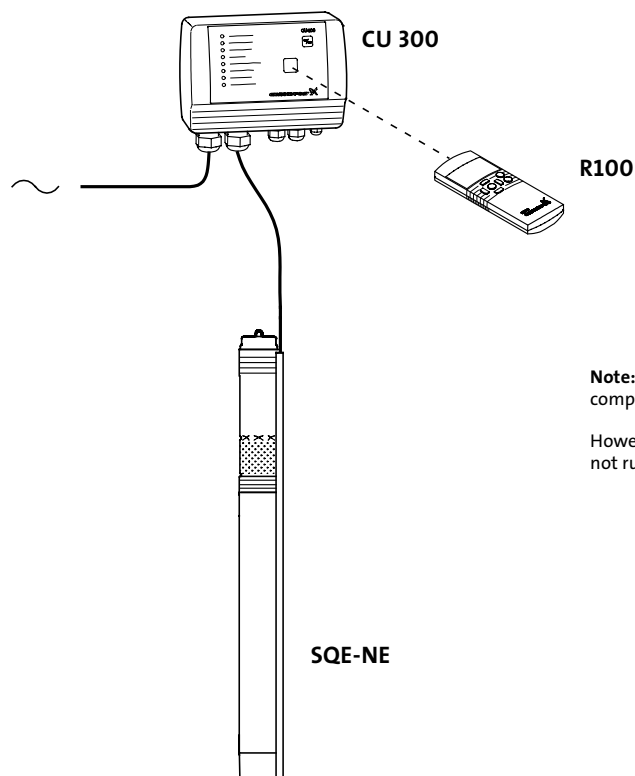

Note: The SQE-NE pump must not be started until the pump has been completely submerged below the water table.

However the change of the motor speed can be made even if the pump is not running.

TM01.8650.4801

Workshop setting of operating parameters

Part	Type	No. of units	Product number	Unit price	Total price
SQE-NE, pump					
Remote control	R100				
Control unit	CU 300				
"SQE Speed Calculation" program					

CU 300 control unit

The CU 300 is a control and communication unit specially developed for the SQE-NE submersible pumps.

The CU 300 control unit provides...

- easy adjustment to a specific borehole,
- full control of the SQE-NE pumps,
- two-way communication with the SQE-NE pumps,
- Alarm indication of pump operation by diodes on the front and
- The possibility of starting, stopping and resetting the pump simply by means of a push-button.

The CU 300 communicates with the pump via the power supply cable. This is called mains borne signalling or power line communication, and using this concept means that no extra cables between the CU 300 and the pump are required.

The following alarms can be indicated by the CU 300:

- No contact
- Overvoltage
- Undervoltage
- Dry running
- Speed reduction
- Overtemperature
- Overload
- Sensor alarm.

The CU 300 incorporates...

- external signal input for two analog sensors and one digital sensor.
- relay output for external alarm indication,
- control according to the signals received, e.g. concerning flow, pressure, water level and conductivity.

Furthermore, the CU 300 offers the possibility of remote control.

R100 remote control

Wireless infrared remote control of the CU 301 is possible by means of the R100.

Using the R100 it is possible to monitor and change the operating parameters, see the R100 menu structure on page 20. The R100 is a strong tool in case fault finding is required.

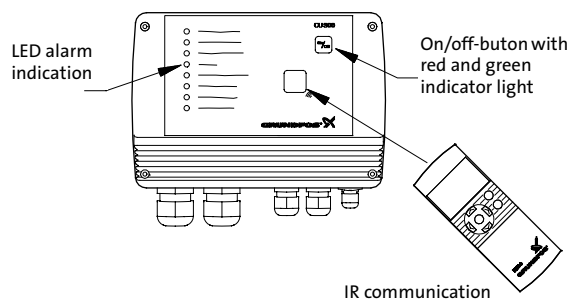

TM01.2760.4801

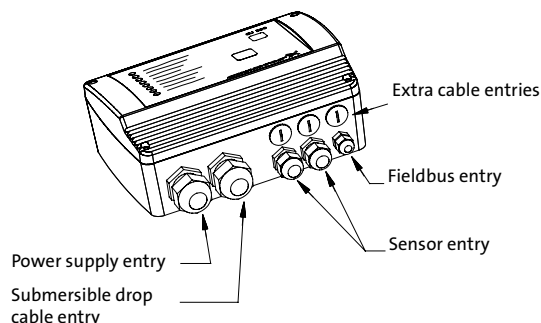

TM01.2761.4801

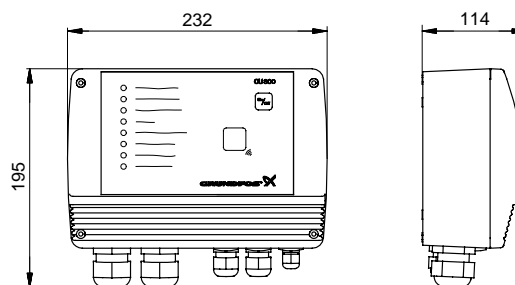

TM01.2781.4601

Dimensions stated in mm.

R100 menu structure for the CU 300

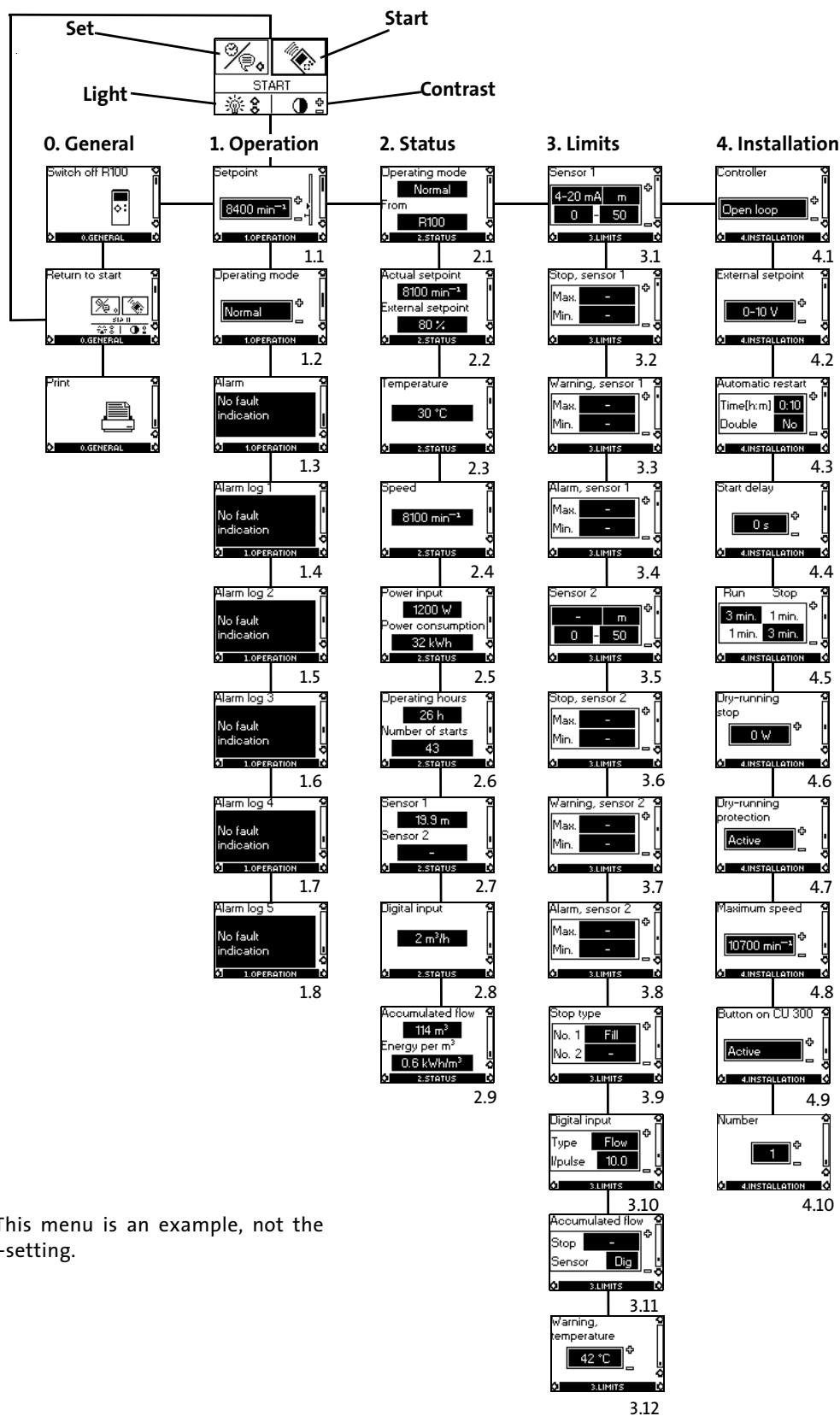

Note: This menu is an example, not the factory-setting.

R100 menus for CU 300

0. General

1. Operation
 - 1.1 Setpoint setting.
 - 1.2 Selection of operating mode.
 - 1.3 Alarm indication.

2. Status

The indication of:

- 2.1 Actual operating mode.
- 2.2 Actual and external setpoint.
- 2.3 Actual motor temperature.
- 2.4 Actual motor speed.
- 2.5 Actual power input and accumulated motor power consumption.
- 2.6 Accumulated number of operating hours and accumulated number of starts.
- 2.7 Actual values of sensors 1 and 2, respectively.
- 2.8 Actual values of the digital input.
- 2.9 Accumulated flow, and the power used to pump 1 m³.

R100 offers the possibility of making a number of settings:

3. Limits

The setting of:

- 3.1 Sensor 1 parameters.
- 3.2 Min. and max. stop limit of sensor 1.
- 3.3 Min. and max. warning limit of sensor 1.
- 3.4 Min. and max. alarm limit of sensor 1.
- 3.5 Sensor 2 parameters.
- 3.6 Min. and max. stop limit of sensor 2.
- 3.7 Min. and max. warning limit of sensor 2.
- 3.8 Min. and max. alarm limit of sensor 2.
- 3.9 Filling or emptying.
- 3.10 Setting of the function of the digital sensor connected to the digital input.
- 3.11 The setting of the water quantity stop limit and the setting of the sensor to detect water quantity.
- 3.12 The setting of the temperature warning limits of the motor electronics.

4. Installation

- 4.1 Selection of controller.
- 4.2 Setting of external setpoint.
- 4.3 Setting of automatic restart time.
- 4.4 Allocation of individual start delays.
- 4.5 Setting of the stop and run times for the dewatering function.
- 4.6 Setting of the dry-running stop limit.
- 4.7 Activating or deactivating the dry-running protection.
- 4.8 Setting of the maximum motor speed.
- 4.9 Activating or deactivating the on/off-button on the CU 300.
- 4.10 Allocation of number where more than one CU 300 is installed.

Status report

All settings and measured values can be transferred to a portable printer via wireless infrared communication and be printed in a status report.

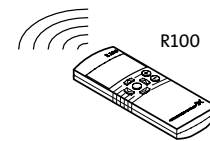
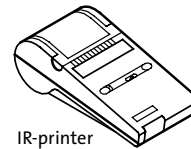

TM00 7982 2293

Examples of R100 displays

Menu OPERATION

Setpoint setting

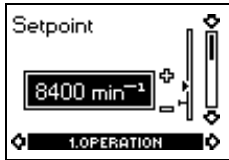

1.1

From factory, the pump is set to maximum speed, 10,700 min⁻¹. R100 makes it possible to reduce the pump speed by changing the setpoint. The speed can be set to 3,000 - 10,700 min⁻¹, at intervals of 100 min⁻¹.

The unit of the setpoint is automatically changed according to the unit of the sensor connected to sensor input No. 1.

Example: Sensor input No. 1 is connected to a pressure sensor using the unit metre (m) and the range 0 - 60. Consequently, the setpoint of display 1.1 can be set to between 0 - 60 m.

Menu STATUS

The displays appearing in this menu are status displays only. It is not possible to change settings in this menu.

Accumulated flow

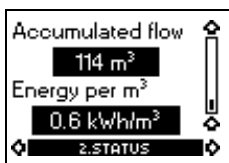

2.9

Display 2.9 shows the water quantity (in m³) pumped. The value shown is the accumulated flow registered by the sensor selected in display 3.11.

The power used to pump 1 m³ is shown in the display as energy per m³ (kWh/m³).

It is possible to read the status of the accumulated flow and energy per m³ at any time.

Accumulated number of operating hours and number of starts



2.6

The value of operating hours and the number of starts are values accumulated from the time of installation, and they cannot be reset.

Both values are stored in the motor electronics, and they are kept even if the CU 300 is replaced.

The number of operating hours is registered every two minutes of continuous operation.

Menu LIMITS

Sensor 1

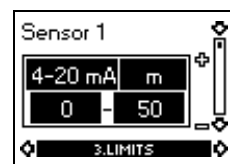

3.1

The setting of sensor 1.

Depending on the type of sensor, the following settings can be made:

- Sensor outputs:
 - (not active), 0-10 V, 2-10 V, 0-20 mA, 4-20 mA.
- Setting range unit:
 - m³/h, m, %, GPM, ft.
- Sensor minimum value: 0 - 249 (0,1,2,3.....249)
- Sensor maximum value: 1 - 250 (1,2,3,4.....250)

Alarm indication

The CU 300 offers the following alarm indications.

Alarm	Description	The pump will be restarted automatically
No contact	No contact/communication between the CU 300 and the SQE-NE pump. Note: This alarm does not affect pump operation.	–
Overvoltage	The supply voltage exceeds the limit value.	when the voltage is within the specified range.
Undervoltage	The supply voltage is below the limit value.	when the voltage is within the specified range.
Dry running	The dry-running protection of the pump has been activated.	after 5 minutes (default), or a period set by R100.
Speed reduction	The motor speed is reduced. Note: The speed is resumed when the cause has been remedied or has disappeared.	–
Overtemperature	The motor temperature exceeds the limit value.	when motor electronics is sufficiently cooled down.
Overload	The current consumption of the motor exceeds the value set.	after 5 minutes (default), or a period set by R100.
Sensor alarm	Sensor alarm may be caused by the following: The measured value has dropped outside the measuring range set. The sensor is defective. The sensor output setting made via R100 is incorrect.	after 5 minutes (default), or a period set by R100.

Benefits of CU 300/R100

Alarm	Description	The following items are no longer required
No contact	Provides knowledge of contact between the SQE-NE pump and the CU 300.	–
Overvoltage	The supply voltage is measured.	Overvoltage relay.
Undervoltage	The supply voltage is measured.	Undervoltage relay.
Dry running	Provides dry-running protection of the booster module.	Level relay, electrodes, cables.
Speed reduction	Ensures pump operation at a moderate undervoltage and overload, thereby ensuring that the motor is not overloaded.	Urgent need for service.
Overtemperature	The pump is stopped at a critical temperature. Once the motor electronics is sufficiently cooled down, the motor will restart automatically.	–
Overload	Provides overload protection of the motor.	Motor starter.
Sensor alarm	Sensors can be connected directly to the CU 300. The sensor signals are monitored.	External control unit.

Determining head and flow

Pump selection should be based on the required flow and head.

1. Flow

Selection of the most suitable pump size should be based on the likely maximum flow of liquid expected to be pumped.

2. Head

- $H [m] = P_{outlet} \times 10.2 + H_{geo} + H_f$
- P_{outlet} = Required pressure at the outlet
- H_{geo} = Difference in attitude between lower water level and the outlet
- H_f = Friction loss in pipes and tubes. See table below.

Calculation example:

Required flow: $3.8 \text{ m}^3/\text{h}$
 $P_{outlet} = 3 \text{ bar}$
 $H_{geo} = 25 \text{ m}$

The pipes which are made of plastic, have a diameter of $\varnothing 32$, and a length of 25 m.

This will give:

$H_f = \text{Value from table}/100 \times \text{length of pipe.}$
 $H_f = 18/100 \times 25 \text{ m} = 4.5 \text{ m}$

$H [m] = P_{outlet} \times 10.2 + H_{geo} + H_f$
 $= 3 \times 10.2 + 25 \text{ m} + 4.5 \text{ m} = 60.1 \text{ m}$

Selected at $Q = 3.8 \text{ m}^3/\text{h}$, $H = 60.1 \text{ m}$

For selection of the optimum pump type, see the next page.

Examples of head losses in plastic pipes and ordinary water pipes: H_f

Note: The material of the riser pipe must be selected according to the pumped liquid.

Upper figures indicate the water velocity in m/sec.
 Lower figures indicate head loss in metres per 100 metres of straight pipes.

Volume of water			Plastic pipes* (PELM/PEH PN 10 PELM)				Ordinary water pipes**				
m ³ /h	Litres/min.	Litres/sec.	Nominal pipe diameter in inches and internal diameter in [mm]								
			25 20.4	32 26.2	40 32.6	50 40.8	½" 15.75	¾" 21.25	1" 27.00	1¼" 35.75	1½" 41.25
0.6	10	0.16	0.49	0.30	0.19	0.12	0.855	0.470	0.292		
			1.8	0.66	0.27	0.085	9.910	2.407	0.784		
0.9	15	0.25	0.76	0.46	0.3	0.19	1.282	0.705	0.438	0.249	
			4.0	1.14	0.6	0.18	20.11	4.862	1.570	0.416	
1.2	20	0.33	1.0	0.61	0.39	0.25	1.710	0.940	0.584	0.331	0.249
			6.4	2.2	0.9	0.28	33.53	8.035	2.588	0.677	0.346
1.5	25	0.42	1.3	0.78	0.5	0.32	2.138	1.174	0.730	0.415	0.312
			10.0	3.5	1.4	0.43	49.93	11.91	3.834	1.004	0.510
1.8	30	0.50	1.53	0.93	0.6	0.38	2.565	1.409	0.876	0.498	0.374
			13.0	4.6	1.9	0.57	69.34	16.50	5.277	1.379	0.700
2.1	35	0.58	1.77	1.08	0.69	0.44	2.993	1.644	1.022	0.581	0.436
			16.0	6.0	2.0	0.70	91.54	21.75	6.949	1.811	0.914
2.4	40	0.67	2.05	1.24	0.80	0.51		1.879	1.168	0.664	0.499
			22.0	7.5	3.3	0.93		27.66	8.820	2.290	1.160
3.0	50	0.83	2.54	1.54	0.99	0.63		2.349	1.460	0.830	0.623
			37.0	11.0	4.8	1.40		41.40	13.14	3.403	1.719
3.6	60	1.00	3.06	1.85	1.2	0.76		2.819	1.751	0.996	0.748
			43.0	15.0	6.5	1.90		57.74	18.28	4.718	2.375
4.2	70	1.12	3.43	2.08	1.34	0.86		3.288	2.043	1.162	0.873
			50.0	18.0	8.0	2.50		76.49	24.18	6.231	3.132
4.8	80	1.33		2.47	1.59	1.02			2.335	1.328	0.997
				25.0	10.5	3.00			30.87	7.940	3.988
5.4	90	1.50		2.78	1.8	1.15			2.627	1.494	1.122
				30.0	12.0	3.50			38.30	9.828	4.927
6.0	100	1.67		3.1	2.0	1.28			2.919	1.660	1.247
				39.0	16.0	4.6			46.49	11.90	5.972
7.5	125	2.08		3.86	2.49	1.59			3.649	2.075	1.558
				50.0	24.0	6.6			70.41	17.93	8.967
9.0	150	2.50			3.00	1.91				2.490	1.870
					33.0	8.6				25.11	12.53
10.5	175	2.92			3.5	2.23				2.904	2.182
					38.0	11.0				33.32	16.66
90° bends, slide valves							1.0	1.0	1.1	1.2	1.3
T-pieces, non-return valves							4.0	4.0	4.0	5.0	5.0

* The table is based on a monogram.
 Roughness, $K = 0.01 \text{ mm}$.
 Water temperature, $t = 10^\circ\text{C}$.

** The data are calculated in accordance with H. Langs' new formula, $a = 0.02$ and on the basis of a water temperature of 10°C . The head loss in bends, slide valves, T-pieces and non-return valves is equivalent to the metres of straight pipes stated in the last two lines of the table.

Pump sizing

Important: The dry-running protection is effective only within the recommended pump duty range, i.e. the bold curves, see the performance curves.

Pump type	Power [kW]	Flow rate Q [m ³ /h] / [l/s]												Max. head [m] (Q = 0 m ³ /h)	Full-load current I _{1/1} [A]		Pipe connection Rp	Length [mm]	
		0.5/ 0.14	1.0/ 0.28	1.5/ 0.42	2.0/ 0.56	2.5/ 0.70	3.0/ 0.83	3.5/ 0.97	4.0/ 1.11	5.0/ 1.39	6.0/ 1.67	7.0/ 1.95	8.0/ 2.22		9.0/ 2.50	230V			200V
		Head [m]																	
SQE 2 - 35 NE	0.4	39	37	35	31	26	19	-	-	-	-	-	-	41	2.9	3.4	1½	747	
SQE 2 - 50 NE	0.6	58	56	52	47	38	26	-	-	-	-	-	-	59	4.2	4.8	1½	747	
SQE 2 - 65 NE	0.8	76	73	68	60	49	34	-	-	-	-	-	-	78	5.3	6.1	1½	774	
SQE 2 - 75 NE	1.0	94	89	83	74	60	42	-	-	-	-	-	-	97	6.6	7.6	1½	828	
SQE 2 - 90 NE	1.2	111	106	98	87	71	50	-	-	-	-	-	-	116	8.1	9.3	1½	864	
SQE 2 - 105 NE	1.4	129	123	113	100	82	58	-	-	-	-	-	-	135	9.5	10.9	1½	891	
SQE 2 - 115 NE	1.6	147	139	128	114	94	66	-	-	-	-	-	-	153	11.0	-	1½	945	
SQE 5 - 15 NE	0.27	-	-	-	-	-	14	13	13	11	8	-	-	16	2.3	2.6	1½	747	
SQE 5 - 25 NE	0.54	-	-	-	-	-	28	27	25	22	17	-	-	31	3.7	4.3	1½	747	
SQE 5 - 35 NE	0.81	-	-	-	-	-	41	39	37	32	24	-	-	46	5.2	6.0	1½	864	
SQE 5 - 45 NE	1.08	-	-	-	-	-	54	52	49	42	32	-	-	61	6.9	8.0	1½	864	
SQE 5 - 55 NE	1.35	-	-	-	-	-	67	64	61	52	40	-	-	76	8.9	10.2	1½	945	
SQE 5 - 65 NE	1.62	-	-	-	-	-	80	77	73	62	47	-	-	90	10.9	-	1½	945	

Diameter of SQE-NE pumps: 74 mm

Example:

Required: Flow rate: 3.8 m³/h => nearest higher value in table is 4.0 m³/h.
Head: 60.1 m => nearest higher value in table is 61 m.

Selected: Pump type: SQE 5- 55 NE (as it offers the best pump efficiency for the required flow and head).
Required pump power input: 1.35 kW.
Full load current: I_{1/1} = 8.9 A at 230 V.
I_{1/1} = 10.2 A at 200 V.
Pipe connection: Rp 1½.
Length: 945 mm

Variable speed

The performance of the SQE-NE pump can be adjusted to a specific duty point within its performance range. This is done by means of CU 300 and R100.

As energy savings can be achieved by reducing the performance to the required speed the SQE-NE pump is ideally suited to applications where the water consumption varies over time and when the duty point is between two pump curves. The curve chart below shows the performance of a SQE 5-55 NE pump at various speeds.

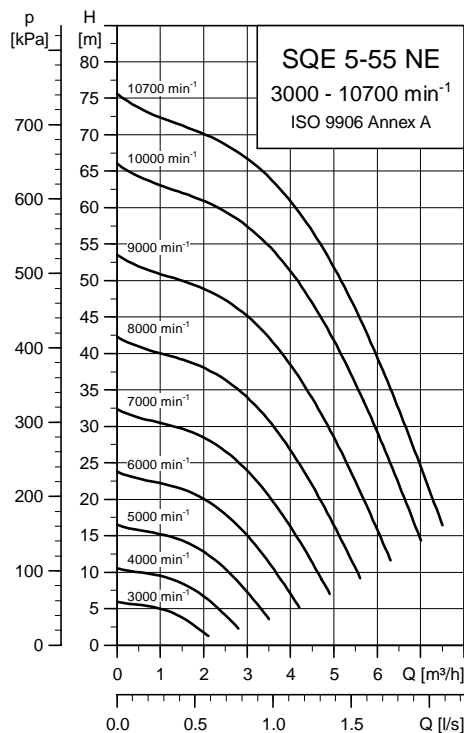

TM02 9919 0405

Example: How to select an SQE-NE pump

- A head of 60.1 m and a flow of 3.8 m³/h is required.
- The optimum pump size is SQE 3-NE. In the curve chart to the right, draw a rightward, horizontal line from the head required 60.1 m (1) to the intersection with the vertical line from the required flow (2). In this example, the intersection point (3) of the two lines is not on one of the pump curves, therefore follow the pipe characteristic upwards. The intersection point of the pump curve and the pipe characteristic (4) gives the size of the pump. The size of the pump is: SQE 5-55 NE.
- The pump power input per stage (P₂) can be read to be 0.26 kW (5), and the pump efficiency is 55% (6) per stage.
- SQE 5-55 NE has 5 stages, see page 37. With 5 stages, the total pump power input for SQE 5-55 NE is 1.3 kW (0.26 kW x 5) which means a 1.1 - 1.73 kW MSE 3-NE motor.

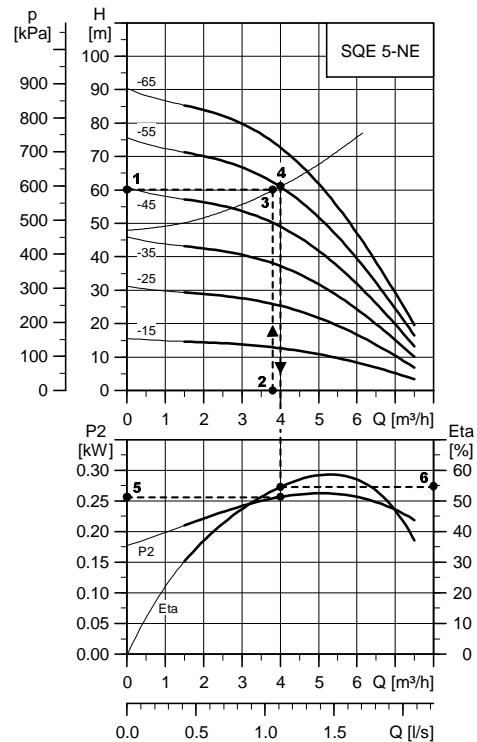

TM02 9920 0405

Curve conditions

The guidelines below apply to the performance curves on pages 34 to 36:

General

- Tolerances are according to ISO 9906, Annex A, i.e. all curves show mean values.
- None of the curves must be used as guarantee curves.
- The **bold** curves show the **recommended** duty range.
- The measurements have been made with airless water at a temperature of 20°C.
- The conversion between head H (m) and pressure p (kPa) applies to water with a density of 1,000 kg/m³.
- The curves apply to a kinematic viscosity of 1 mm²/s (1 cSt). If the pump is used for liquids with a viscosity higher than that of water, this will reduce the head and increase the power consumption.
- **Q/H:** The curves are inclusive of valve and inlet losses at the actual speed. Operation without non-return valve will increase the actual head at nominal performance by 0.5 to 1.0 m.
- **Power curve:** P₂ curve shows pump power input at the actual speed each individual pump size.
- **Efficiency curve:** Eta curve shows pump efficiency per stage.

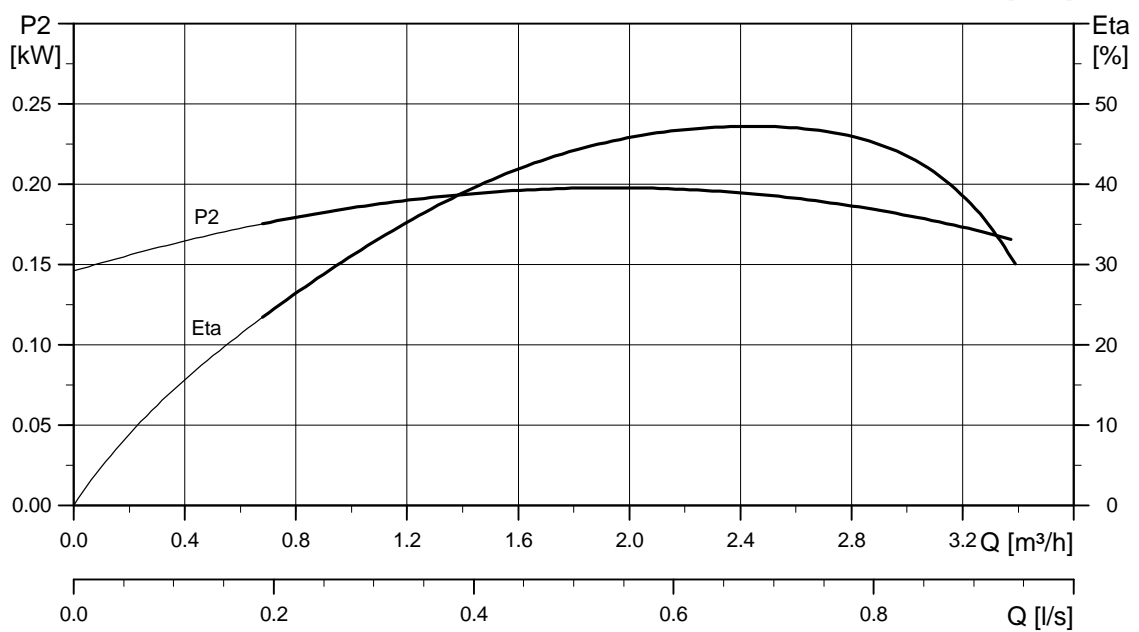
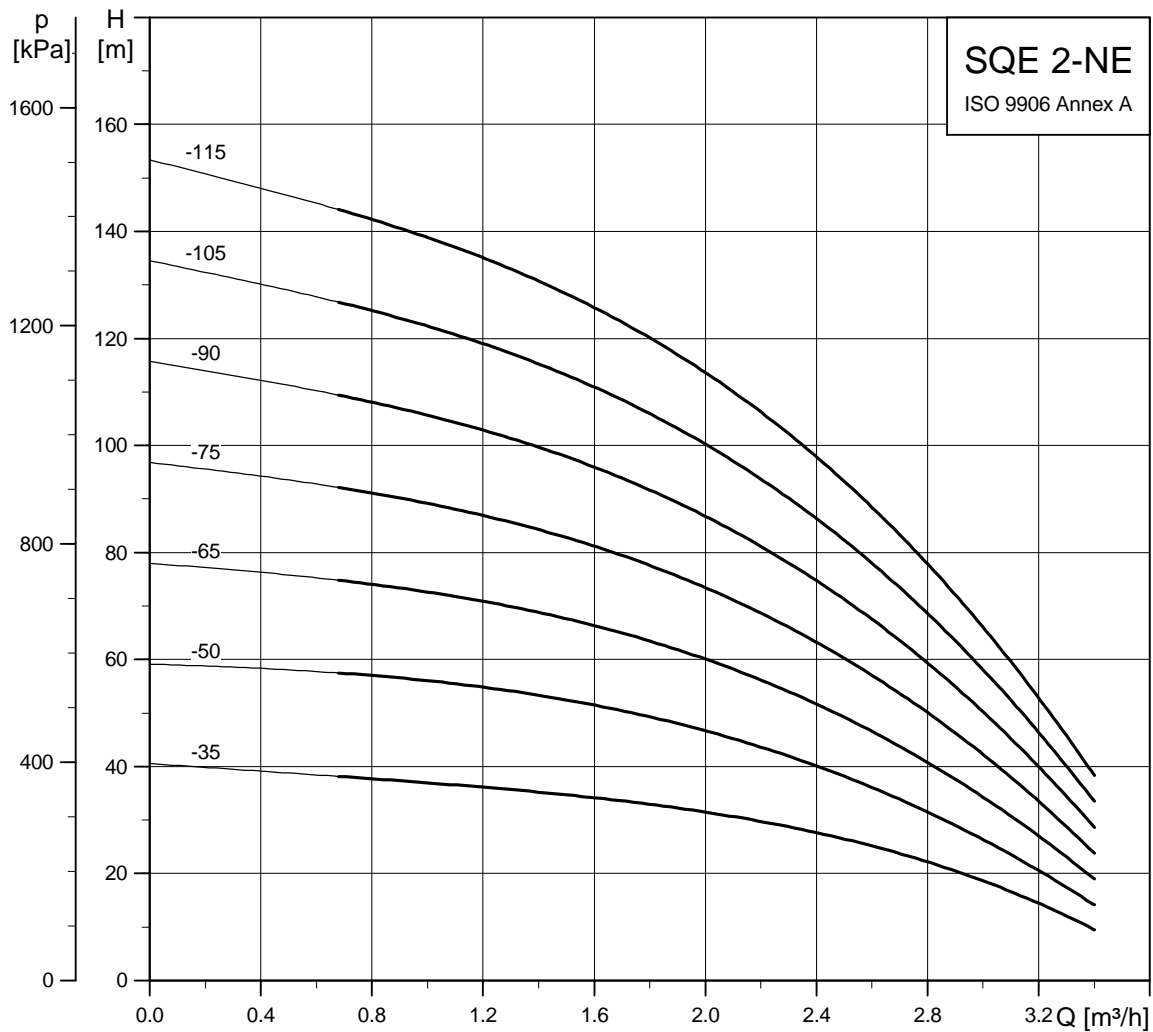

TM01.7399 2500

Dimensions and weights

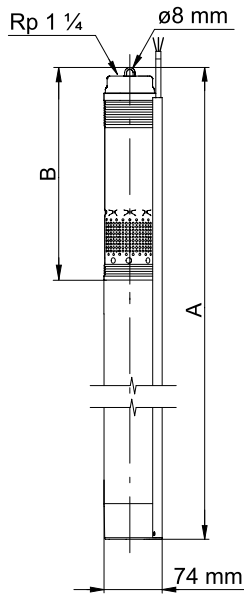

Pump type	Number of stages	Motor		Dimensions [mm]		Net weight [kg]★	Shipping volume [m ³]★
		Type	Output power (P ₂) [kW]	A	B		
SQE 2 - 35 NE	2	MSE 3-NE	0.1 - 0.63	744	268	4.7	0.0092
SQE 2 - 50 NE	3	MSE 3-NE	0.1 - 0.63	744	268	4.8	0.0092
SQE 2 - 65 NE	4	MSE 3-NE	0.7 - 1.05	771	295	5.4	0.0094
SQE 2 - 75 NE	5	MSE 3-NE	0.7 - 1.05	825	349	5.5	0.0100
SQE 2 - 90 NE	6	MSE 3-NE	1.1 - 1.73	825	349	6.2	0.0104
SQE 2 - 105 NE	7	MSE 3-NE	1.1 - 1.73	888	376	6.3	0.0107
SQE 2 - 115 NE	8	MSE 3-NE	1.1 - 1.73	942	430	6.4	0.0113

★including pump, motor and cable guard.

Electrical data

1 x 200-240 V, 50/60 Hz

Pump type	Motor type	Input power, motor (P ₂) [kW]	Output power, motor (P ₂) [kW]	Required input power, pump [kW]	Full-load current I _{1/1} [A]		Full-load motor efficiency (η) [%]
					230 V	200 V	
SQE 2 - 35 NE	MSE 3-NE	0.6	0.1 - 0.63	0.4	2.9	3.4	70
SQE 2 - 50 NE	MSE 3-NE	0.9	0.1 - 0.63	0.6	4.2	4.8	70
SQE 2 - 65 NE	MSE 3-NE	1.15	0.7 - 1.05	0.8	5.3	6.1	73
SQE 2 - 75 NE	MSE 3-NE	1.45	0.7 - 1.05	1.0	6.6	7.6	73
SQE 2 - 90 NE	MSE 3-NE	1.7	1.1 - 1.73	1.2	8.1	9.3	74
SQE 2 - 105 NE	MSE 3-NE	2.0	1.1 - 1.73	1.4	9.5	10.9	74
SQE 2 - 115 NE	MSE 3-NE	2.3	1.1 - 1.73	1.6	11.0	–	74

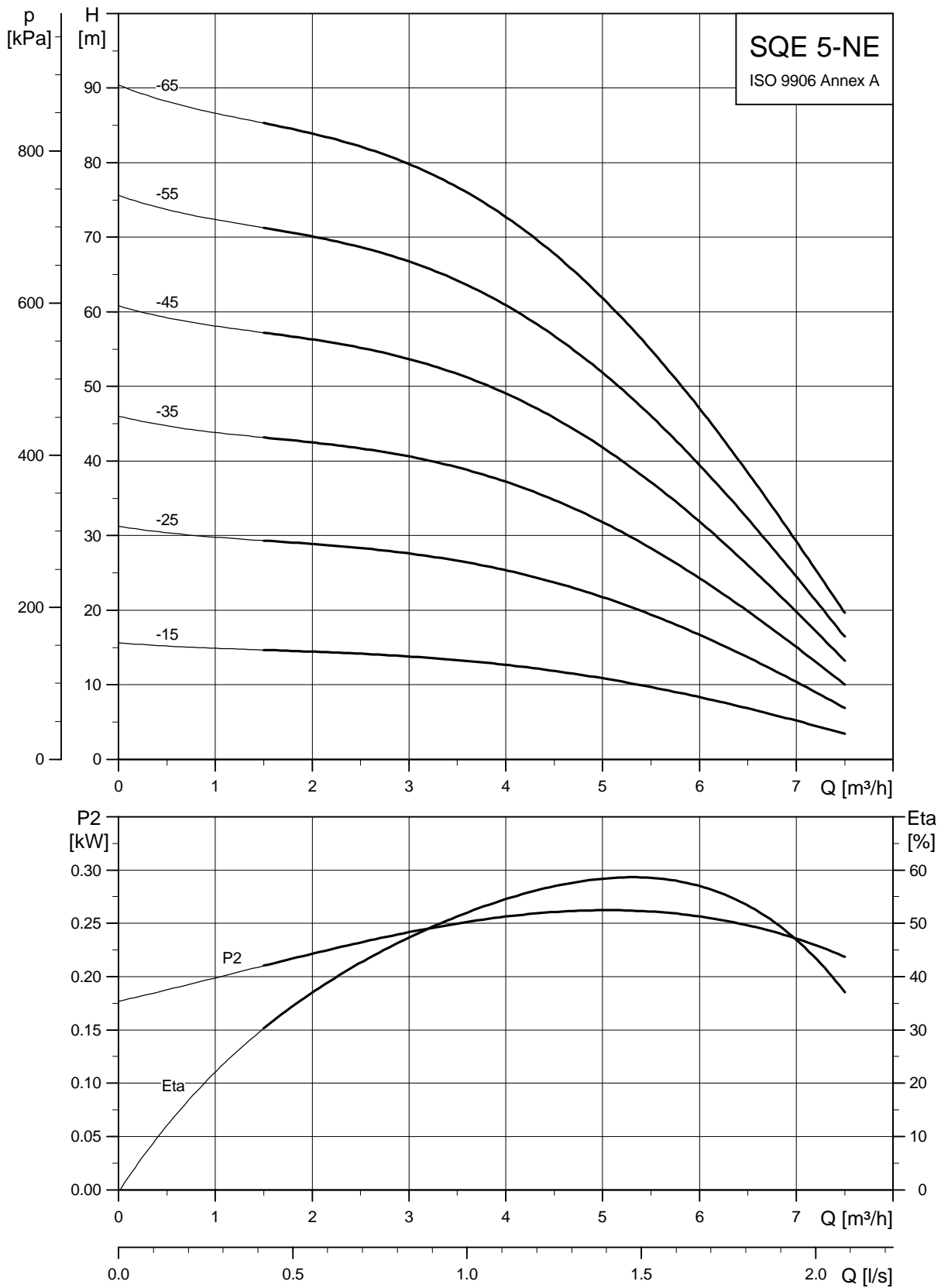

TM01.7401.2500

Dimensions and weights

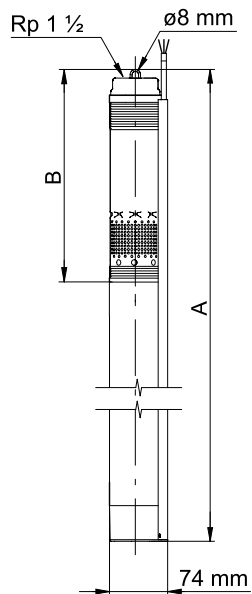

Pump type	Number of stages	Motor		Dimensions [mm]		Net weight [kg]★	Shipping volume [m ³]★
		Type	Output power (P ₂) [kW]	A	B		
SQE 5 - 15 NE	1	MSE 3-NE	0.1 - 0.63	744	268	4.7	0.0100
SQE 5 - 25 NE	2	MSE 3-NE	0.1 - 0.63	744	268	4.8	0.0100
SQE 5 - 35 NE	3	MSE 3-NE	0.1 - 0.63	825	295	5.5	0.0113
SQE 5 - 45 NE	4	MSE 3-NE	0.7 - 1.05	825	349	5.5	0.0113
SQE 5 - 55 NE	5	MSE 3-NE	1.1 - 1.73	942	430	6.4	0.0092
SQE 5 - 65 NE	6	MSE 3-NE	1.1 - 1.73	942	430	6.4	0.0092

★including pump, motor and cable guard.

Electrical data

1 x 200-240 V, 50/60 Hz

Pump type	Motor type	Input power, motor (P ₂) [kW]	Output power, motor (P ₂) [kW]	Required input power, pump [kW]	Full-load current I _{1/1} [A]		Full-load motor efficiency (η) [%]
					230 V	200 V	
SQE 5 - 15 NE	MSE 3-NE	0.5	0.1 - 0.63	0.26	2.3	2.6	70
SQE 5 - 25 NE	MSE 3-NE	0.8	0.1 - 0.63	0.52	3.7	4.3	70
SQE 5 - 35 NE	MSE 3-NE	1.1	0.7 - 1.05	0.78	5.2	6.0	70
SQE 5 - 45 NE	MSE 3-NE	1.5	0.7 - 1.05	1.04	6.9	8.0	73
SQE 5 - 55 NE	MSE 3-NE	1.9	1.1 - 1.73	1.30	8.9	10.2	74
SQE 5 - 65 NE	MSE 3-NE	2.25	1.1 - 1.73	1.56	10.9	–	74

Pump, SQE-NE

Mains supply to pump	1 x 200-240 V –10%/+6%, 50/60 Hz, PE.
Starting	Soft starting.
Stopping	Soft stopping when stopped by means of the CU 300.
Run-up time	Maximum: 3 seconds. No limitation to the number of starts/stops per hour.
Motor protection	Built into the pump. Protection against: Dry running Overvoltage and undervoltage ; the motor cuts out below 150 V and above 280 V Overload Overtemperature
Sound pressure level	The sound pressure level is lower than the limiting values stated in the EEC Machinery Directive.
Radio noise	SQE-NE complies with EMC Directive 89/336/EEC. Approved according to EN 50081-1 and 50082-2.
Reset function	SQE-NE pumps can be reset via CU 300 (possibly by means of R100).
Power factor	PF = 1
Operation via generator	It is recommended that the generator output is equal to the motor input power P_1 [kW] plus 50%; min. $P_1 + 10\%$, however.
Earth leakage circuit breaker	If the pump is connected to an electric installation where an earth-leakage circuit breaker (ELCB) is used as an additional protection, this circuit breaker must trip out when earth fault currents with pulsating DC content occur.
Pipe connection	SQE 2-NE: Rp 1½ SQE 5-NE: Rp 1½
Borehole diameter	Minimum: 76 mm. Maximum: 150 m below static water table (15 bar).
Installation depth	For horizontal installation, a flow sleeve is recommended. Installation depth below dynamic water level: Vertical installation with/without flow sleeve: 0.5 m. Horizontal installation with/without flow sleeve: 0.5 m.
NPSH	Max. 8 m
Strainer	Holes in the strainer: $\varnothing 2.3$ mm
Liquid temperature	30°C: Flow velocity past the motor, 0.0 m/s (free convection). 40°C: Flow velocity past the motor, min. 0.15 m/s.
Pumped liquids, SQE-NE	pH: 2 to 13. Sand contents: Maximum 50 g/m ³ . A larger sand content will considerably reduce the life of service parts.

Control unit, CU 300

Supply voltage	1 x 200-240 V –10%/+6%, 50/60 Hz, PE
Power consumption	5 W
Current consumption	Maximum 130 mA
Enclosure class	IP 55
Ambient temperature	In operation: –30°C to +50°C In store: –30°C to +60°C
Relative air humidity	Maximum: 95%
Pump cable	Maximum cable length between CU 300 and pump: 200 m
Back-up fuse	Maximum: 16 A
Radio noise	CU 300 complies with EMC Directive 89/336/EEC. Approved according to the standards EN 55 014 and 55014-2.
Marking	CE
Sensor input	0-20 mA 4-20 mA 0-10 VDC 2-10 VDC
Load	Max. 100 mA

Material specification (pump)

Pos.	Component	Material	DIN W.-Nr.	AISI
1	Valve casing	PVDF CN-F		
1a	Discharge chamber	Stainless steel	1.4401	316
1d	O-ring	FKM		
4	Top chamber	PVDF CN-F		
6	Top bearing	FKM		
7	Neck ring	PVDF CN-F		
7a	Lock ring	Stainless steel	1.4401	316
8	Bearing	Ceramics		
10	Bottom chamber	PVDF CN-F		
13	Impeller with tungsten carbide bearing	PVDF CN-F		
14	Suction interconnector	PVDF CN-F		
16	Shaft with coupling	Stainless steel Sintered steel	1.4401	316
18	Cable guard	Stainless steel	1.4401	316
18a 18b	Screws for cable guard	Stainless steel	1.4401	316
32	Guide vanes	PVDF CN-F		
30	Cone for pressure equalisation	PVDF CN-F		
55	Pump sleeve	Stainless steel	1.4401	316
75	Priming screw	PVDF CN-F		
86	Lip seal	FKM rubber		

Material specification (motor)

Pos.	Component	Material	DIN W.-Nr.	AISI
201	Stator	Stainless steel	1.4401	316
202	Rotor	Stainless steel	1.4401	316
202a	Stop ring	PP		
202b	Filter	Polyester		
203	Thrust bearing	Carbon		
205	Radial bearing	Ceramics/ tungsten carbide		
222a	Filling plug	FKM		
223	Electronic unit			
224	O-ring	FKM		
225	Top cover	PPS		
232	Shaft seal	FKM		
250	Nut (M4)	Stainless steel	1.4401	316
	Motor liquid	SML-2		

Material specification (cable)

Pos.	Component	Material	DIN W.-Nr.	AISI
1	Rubber plug	FKM		
2	Plate	Stainless steel	1.4401	316
3	Filling compound	Polyurethane		
4	Housing	PVDF CN-F		
5	Cable	ETFE		
	4 nuts (M4)	Stainless steel	1.4401	316

SQE-NE

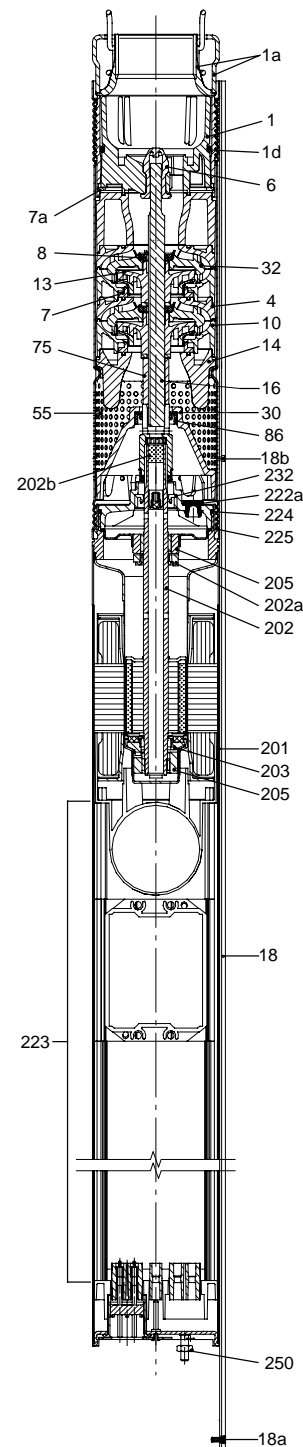

Cable with plug

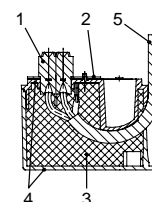

TM01 9171.1300

Wiring diagrams

Mains connection of pump via pressure switch

The motor incorporates a starter device and may therefore be connected directly to the mains supply. Start/stop of the pump will typically be done via a pressure switch.

Note: The pressure switch must be sized for the maximum current of the specific pump type.

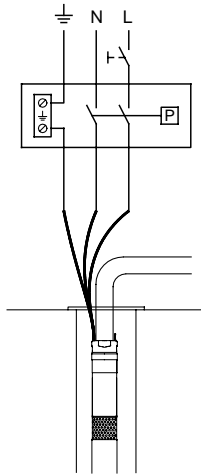

TM01 1480 4697

Electrical connection of CU 300

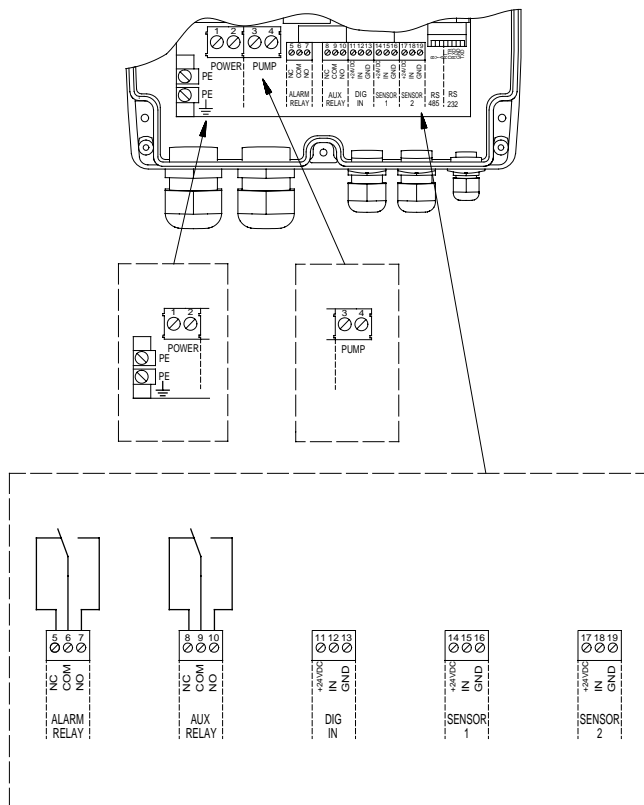

Alarm relay:

Potential-free changeover contact
Maximum contact load: AC 250 V,
Max. current 1A
Minimum contact load: DC 5 V, 10 mA

Auxiliary relay:

Potential-free changeover contact
Maximum contact load: Safety extra-low voltage to be used only.
Max. current 1A
Minimum contact load: DC 5 V, 10 mA

Digital input:

External potential-free contact
Logic "0": $U_{in} > 3.2 V$
Logic "1": $U_{in} < 0.9 V$

Sensor 1:

Voltage signal: DC 0 - 10 V/2 - 10 V, $R_i = 11 k\Omega$.
Tolerance: $\pm 3\%$ at maximum voltage signal.
Screened cable recommended, maximum length of cable: 500 m.

Current signal: DC 0 - 20 mA/4 - 20 mA, $R_i = 500 \Omega$.
Tolerance: $\pm 3\%$ at maximum current signal.
Screened cable recommended, maximum length of cable: 500 m.

Sensor 2:

Potentiometer: DC 0 - 24 V, 10 k Ω (via internal voltage supply).
Screened cable is recommended, maximum length of cable: 100 m.

Voltage signal: DC 0 - 10 V/2-10 V, $R_i = 11 k\Omega$. Tolerance:
 $\pm 3\%$ at maximum voltage signal.
Screened cable recommended, maximum length of cable: 500 m.

Current signal: DC 0 - 20 mA/4 - 20 mA, $R_i = 500 \Omega$.
Tolerance: $\pm 3\%$ at maximum current signal.
Screened cable recommended, maximum length of cable: 500 m.

TM01 3008 2898

Straining wire



TM00 7897 2296

Description	Version	Product no.
Stainless steel DIN W.-Nr. 1.4401. Secures the submersible pump during installation. When ordering please state length [mm].	Diameter: 2 mm Admissible load: 100 kg	ID8957

Wire clamp



TM00 7898 2296

Description	Version	Product no.
Stainless steel DIN W.-Nr. 1.4401.	Two clamps per loop	00ID8960

CU 300, control unit

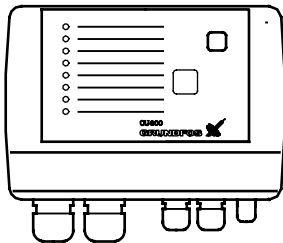

TM01 4356 0199

Description	Product no.
CU 300 control unit provides full control of the SQE-NE pump. Language specific CU 300 versions available on request.	96422775 (English)

R100 remote control

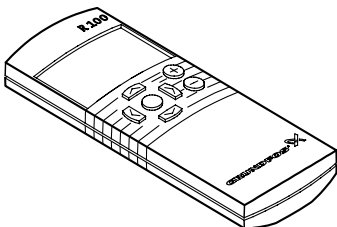

TM00 8367 4801

Description	Product no.
The R100 is used for wireless communication with CU 300. Communication takes place by means of infrared light.	625333

Printer

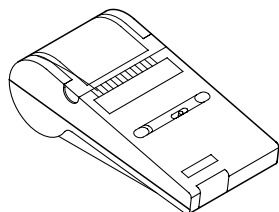

TM00 8368 2796

Description	Product no.
Printer for R100, infrared communication. Type: Hewlett Packard, HP 82240B.	620480
Paper rolls, 5 pcs.	620481

Potentiometer

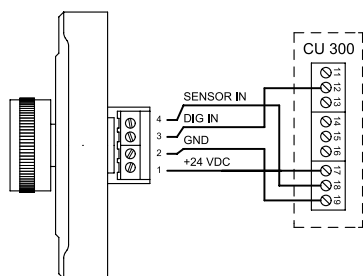
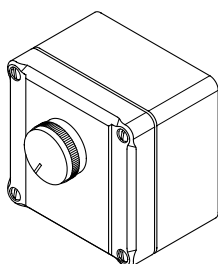

TM00 2604 4793 - TM01 3291 3798

Description	Version	Product no.
External potentiometer with cabinet for wall mounting. Screened cables, 4-wire cable. Max. length of cable: 100 m	Grundfos potentiometer, SPP1. Enclosure class: IP 55	625468

SQE Speed calculation program

Type	Beskrivelse	Produktnr.
PC Tool "SQE Speed Calculation"	<ul style="list-style-type: none"> SQE speed calculation program (Windows 95) CD-ROM Operating manual 	96478266

Sensors

Sensors	Supplier	Type	Measuring range	Product no.
Level sensor, including 30 m cable ★	JUMO	4390-242	0 - 2.5 bar	96037489
Level sensor, including 65 m cable ★	JUMO	4390-242	0 - 6 bar	96037490
Level sensor, including 105 m cable ★	JUMO	4390-242	0 - 10 bar	96037491
Pressure switch	Condor	mdr 21/6	1 - 6 bar	ID6462
Flow switch unit (SQE 2)	Grundfos	mdr 21/6 1"	0 - 5 m ³ /h	96037332
Flow switch unit (SQE 5)	Grundfos	FS 200	5 - 7 m ³ /h	96037559
Flow meter (pulsating) 1 l/pulse	Bdr. Dahl	QN 2.5	0 - 5 m ³ /h	96037492
Flow meter (pulsating) 2.5 l/pulse	Bdr. Dahl	QN 6	0 - 12 m ³ /h	96037583
Flow meter (pulsating) 5 l/pulse	Bdr. Dahl	QN 10	0 - 20 m ³ /h	96037584
Pressure sensor kit for CU 300 incl. 2 m cable	Danfoss	MBS 3000	0 - 4 bar	405160
			0 - 6 bar	405161
Pressure sensor kit for CU 301 incl. 2 m cable	Grundfos	Grundfos type	0 - 6 bar	96437851

★ Made of PE, the cable is only suitable for short time use in pumped liquids containing organic solvents.

Product numbers

The pump is supplied complete with motor and cable guard fitted, but without the cable with plug, which must be ordered separately.

SQE-NE

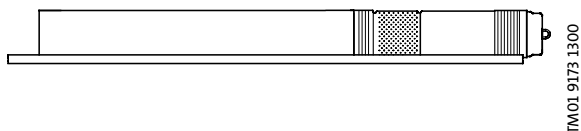

SQE 2-NE

Pump type	Motor		Product number
	Type	P ₂ [kW]	
SQE 2 - 35 NE	MSE 3-NE	0.1 - 0.63	96033916
SQE 2 - 50 NE	MSE 3-NE	0.1 - 0.63	96033917
SQE 2 - 65 NE	MSE 3-NE	0.7 - 1.05	96033926
SQE 2 - 75 NE	MSE 3-NE	0.7 - 1.05	96033927
SQE 2 - 90 NE	MSE 3-NE	1.1 - 1.73	96033936
SQE 2 - 105 NE	MSE 3-NE	1.1 - 1.73	96033999
SQE 2 - 115 NE	MSE 3-NE	1.1 - 1.73	96033937

SQE 5-NE

Pump type	Motor		Product number
	Type	P ₂ [kW]	
SQE 5 - 15 NE	MSE 3-NE	0.1 - 0.63	96033920
SQE 5 - 25 NE	MSE 3-NE	0.1 - 0.63	96033921
SQE 5 - 35 NE	MSE 3-NE	0.7 - 1.05	96033930
SQE 5 - 45 NE	MSE 3-NE	0.7 - 1.05	96033941
SQE 5 - 55 NE	MSE 3-NE	1.1 - 1.73	96033942
SQE 5 - 65 NE	MSE 3-NE	1.1 - 1.73	96033943

Cable kits for waste dumps

Note: The cable must be ordered separately.

The cables are available in various lengths, see table below:

Cable length [m]	Net weight [kg]	Shipping volume [m ³]	Product number
5	0.8	0.0006	96160883
10	1.4	0.0246	96160884
15	2.0	0.0246	96160885
20	2.6	0.0246	96160886
30	3.8	0.0246	96160887
40	5.0	0.0246	96160888
50	6.3	0.0246	96160889
60	7.5	0.0476	96160890
70	8.7	0.0476	96160891
80	9.9	0.0476	96160892

Performance range

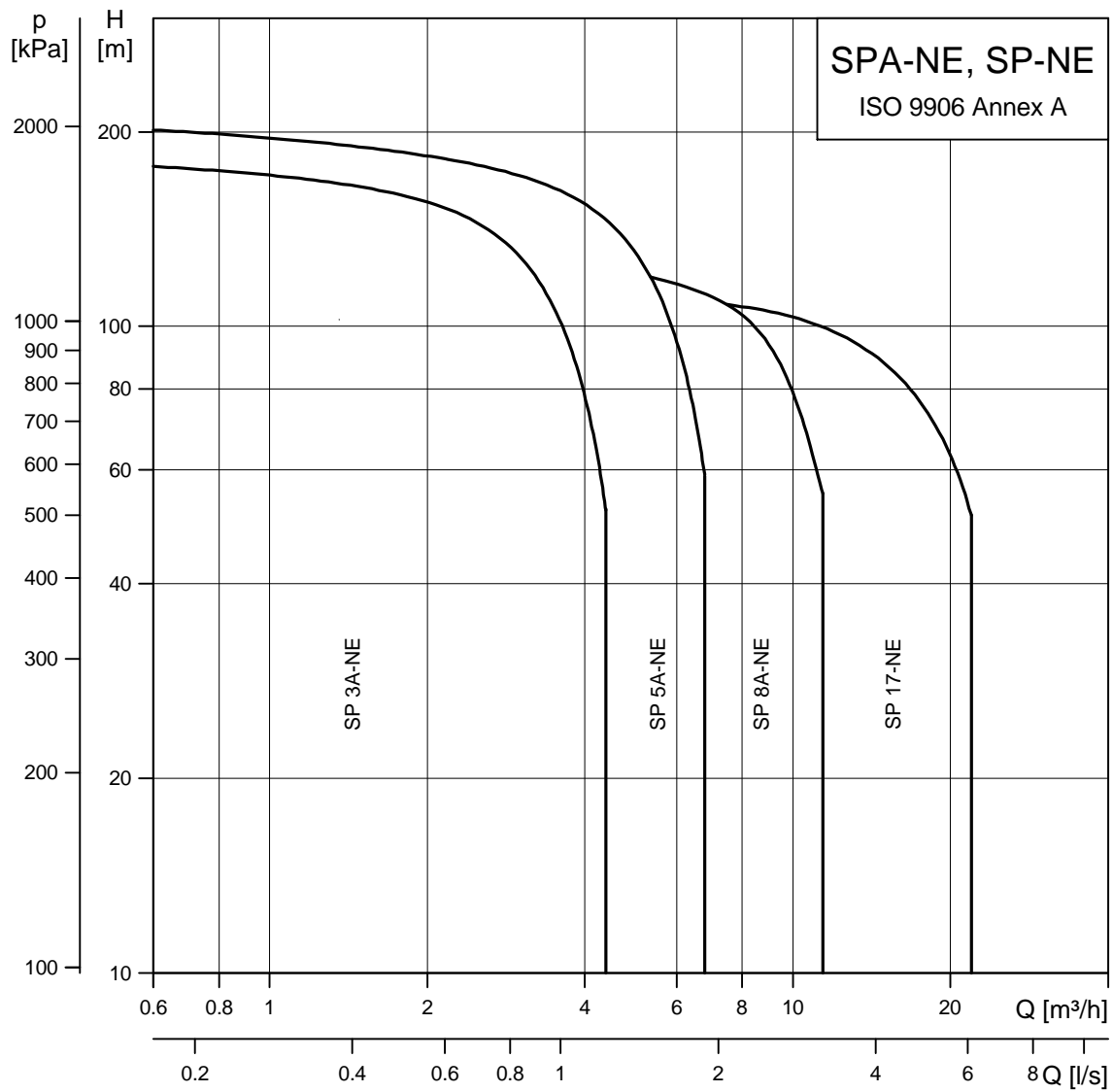

TM00 0520 2400

Pump

Pump type	Pump diameter [mm]	Pipe connection
SP 3A-NE	101	Rp 1½
SP 5A-NE	101	Rp 1½
SP 8A-NE	101	Rp 2
SP 17-NE	131	Rp 2½

Multistage, centrifugal pump with radial impellers directly coupled to a Grundfos submersible motor. The pump is made of stainless steel and has water-lubricated, FKM rubber bearings.

Motor

The 2-pole, asynchronous, squirrel-cage MS 4000 RE motor of the canned type with journal bearings is made entirely of stainless steel. Electric tolerances comply with VDE 0530.

All motors have a diameter of 95 mm.

Type designation for RE means the following:

R: The motor is suitable for aggressive and slightly contaminated/polluted liquids, including liquids containing oils. Materials in stainless steel DIN W.-Nr. 1.4539.

E: Suitable for contaminated/polluted liquid (Environmental)

Insulation class:	F.
Enclosure class:	IP 58.
Standard voltages:	1 x 220-230 V, 50 Hz 1 x 240 V, 50 Hz 3 x 200 V, 50 Hz 3 x 220 V, 50 Hz 3 x 380-415 V, 50 Hz 3 x 500-525 V, 50 Hz

The motor cable is enclosed in PTFE and is one long cable without joints for increased cable life. Ceramic shaft seals are resistant to oils and chemicals.

Pumped liquids

Thin, non-explosive liquids without abrasive particles or fibres.

Maximum content of sand: 50 g/m³.

Note: As the SP Environmental pump has not been approved as explosion-proof, local authorities and regulations should be consulted in cases where there is any doubt whether the SP Environmental pump may be used.

Operating conditions

Flow:	0.1-22 m ³ /h
Head:	Max. 200 m
Operating pressure:	Max. 6.0 MPa (60 bar)
Max. transportation and storage temperature:	-20°C to +60°C
Max. liquid temperature:	See table below.

Motor	Max. temperature of pumped liquid		
	Flow velocity past motor	Vertical	Horizontal
MS 4000 RE	Free convection 0.0 m/s	20°C	Flow sleeve recommended
MS 4000 RE	0.15 m/s	40°C	40°C

Features and benefits

Bearings with sand channels

All bearings are lubricated by the pumped liquid. The channels formed by the internal square along the shaft allow sand to be carried away by the pumped liquid.



TM00 7301 1096

Inlet strainer

The inlet strainer prevents entry of particles over a certain size.

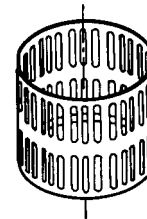

TM00 7302 1096

Priming disc

The Grundfos SPA-NE, SP-NE pumps are fitted with a priming disc. Consequently, dry running is prevented, as the priming disc will ensure lubrication of pump bearings during operation. The priming disc for the SPA-NE pump is shown to the right.

However, if the water table is lowered to a level below the pump inlet neither pump nor motor will be protected against dry running.

Protection against upthrust

The stop ring prevents damage to the pump during transportation and in case of up-thrust in connection with start-up.

Designed as a thrust bearing the stop ring limits axial movement of the pump shaft.



TM01 9543 2100

Service

The modular pump and motor design facilitates installation and service. The cable with plug is fitted to the motor with a nut which facilitates replacement.

Only pumps that can be certified as uncontaminated, ie pumps containing no hazardous and/or toxic material, may be returned to Grundfos for servicing.

To prevent injury to the health of persons involved and to the environment, a document certifying that the pump is clean is required.

Grundfos must receive this certificate before the product. Otherwise Grundfos will refuse to accept the product for servicing. Possible costs of returning the product are paid by the customer.

Overtemperature protection

Accessories for protection against overtemperature is available for the MS 4000 RE submersible motors. When the temperature becomes too high, the protection device will cut out the motor thus preventing damage to pump and motor.

Restart of the motor after cut-out can take place in two ways:

- manual restart or
- automatic restart.

Automatic restart means that the CU 3 attempts to restart the motor after 15 minutes. If the first attempt is not successful, restarting will be reattempted at intervals of 30 minutes.

The Grundfos MS submersible motors are available with a built-in Tempcon temperature transmitter for protection against overtemperature. By means of the transmitter, it is possible to read out and/or monitor the motor temperature via an MTP 75 or a CU 3 control unit via R100.

Protection against upthrust

In case of a very small counter pressure in connection with start-up there is a risk that the entire pump body may rise. This is called upthrust and it may damage both pump and motor. Therefore both Grundfos pumps and motors are protected against upthrust as standard, preventing upthrust from occurring in the critical start-up phase. The protection consists of either a built-in stop ring or a hydraulic balancing device.

Built-in cooling chambers

In all Grundfos MS submersible motors type RE, efficient cooling is ensured by means of cooling chambers fitted at the top and at the bottom of the motor, and by internal circulation of motor liquid, see drawing to the right. As long as the required flow velocity past the motor is maintained (see "Operating conditions" page 53) cooling of the motor will be efficient.

Example: MS 4000 RE

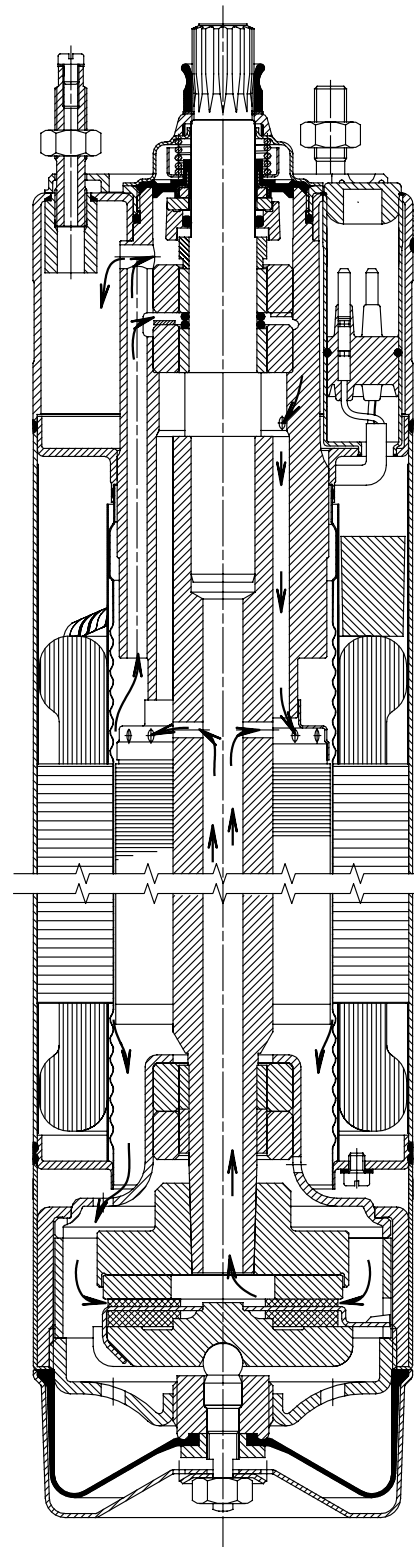

TM00 5698 0996

Reduced risk of short-circuit

The embedded stator winding in the Grundfos MS submersible motor, type RE is hermetically enclosed in stainless steel. The result is high mechanical stability and optimum cooling. In addition the risk of short-circuit of the windings caused by condensed water is eliminated.

Shaft seal

The ceramic/tungsten carbide shaft seal provides optimum sealing and wear resistance as well as long life.

The large surface as well as the sand shield of the spring-loaded shaft seal ensure minimum exchange of pumped liquid and motor liquid and no penetration of particles.

Example: MS 4000

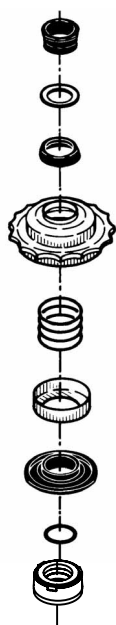

TM00 7306 2100

Curve conditions

The conditions below apply to the curves shown on the following pages:

General

- Curve tolerances are according to ISO 9906, Annex A.
- The performance curves show pump performance at actual speed, cf. standard motor range. The speed of 4" motors is approximately as follows: $n = 2870 \text{ min}^{-1}$.
- The measurements have been made with airless water at a temperature of 20°C. The curves apply to a kinematic viscosity of $1 \text{ mm}^2/\text{s}$ (1 cSt). When pumping liquids with a density higher than that of water, a motor with a correspondingly higher output must be used.
- The **bold** curves shows the **recommended** performance range.
- The performance curves are inclusive of possible losses such as non-return valve loss.

SP curves

- **Q/H:** The curves are inclusive of valve and inlet losses at the actual speed. Operation without non-return valve will increase the actual head at nominal performance by 0.5 to 1.0 m.
- **Power curve:** The P_2 -curve shows pump power input at the actual speed each individual pump size.
- **Efficiency curve:** Eta-curve shows pump efficiency per stage.

Performance curves

Submersible pumps
SP 3A-NE

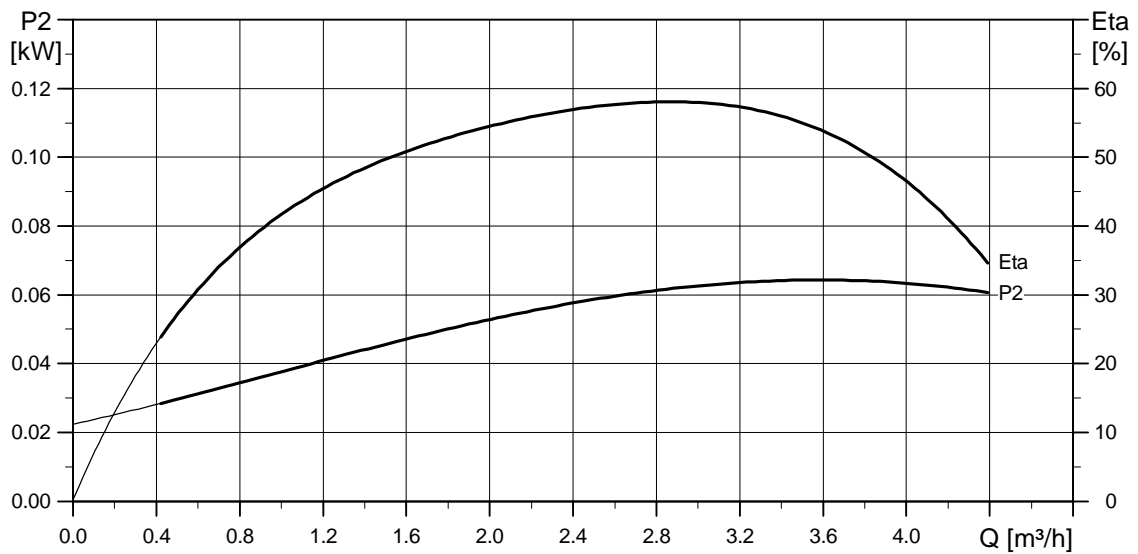
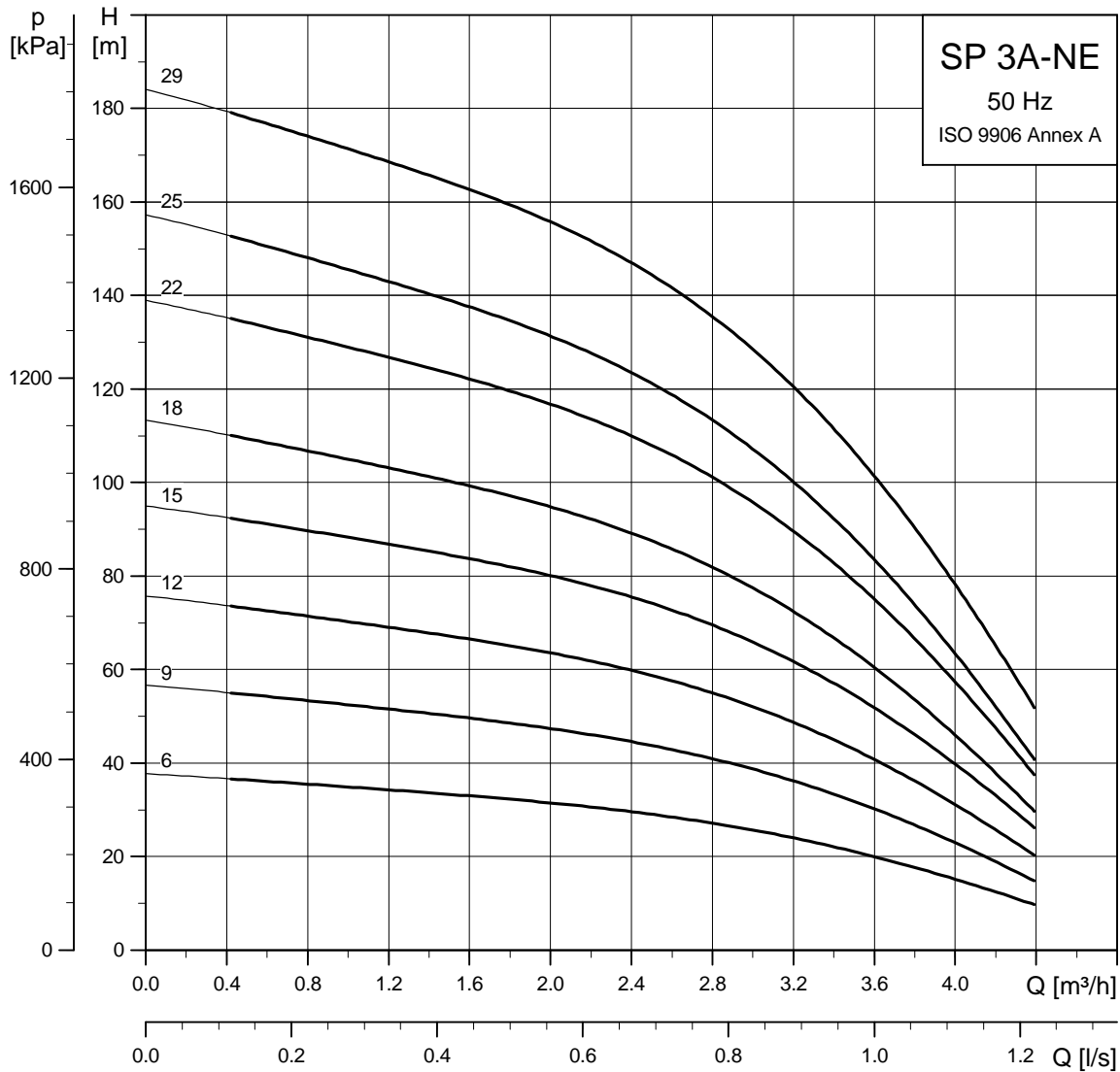

TM01 3498 2500

Dimensions and weights

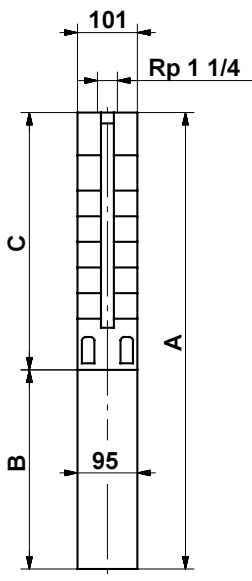

TM00 09551196

101 mm = Maximum diameter of pump, inclusive of cable guard and motor

Pump type	Motor			Dimensions [mm]				Net weights [kg]	
	Type	Power [kW]	C	B		A		1x230 V	3x400 V
				1x230 V	3x400 V	1x230 V	3x400 V		
SP 3A-6 NE	MS 4000 RE	2.2	326	573		899		26	
SP 3A-6 NE	MS 4000 RE	0.75	326		398		724		18
SP 3A-9 NE	MS 4000 RE	2.2	389	573		962		27	
SP 3A-9 NE	MS 4000 RE	0.75	389		398		787		19
SP 3A-12 NE	MS 4000 RE	2.2	452	573		1025		28	
SP 3A-12 NE	MS 4000 RE	0.75	452		398		850		20
SP 3A-15 NE	MS 4000 RE	2.2	515	573		1088		29	
SP 3A-15 NE	MS 4000 RE	1.1	515		413		928		22
SP 3A-18 NE	MS 4000 RE	2.2	578	573		1151		30	
SP 3A-18 NE	MS 4000 RE	1.1	578		413		991		23
SP 3A-22 NE	MS 4000 RE	2.2	662	573		1235		31	
SP 3A-22 NE	MS 4000 RE	1.5	662		413		1075		24
SP 3A-25 NE	MS 4000 RE	2.2	725	573		1298		32	
SP 3A-25 NE	MS 4000 RE	1.5	725		413		1138		25
SP 3A-29 NE	MS 4000 RE	2.2	809	573	453	1382	1262	33	28

Electrical data

3 x 400 V, 50 Hz

Pump type	Motor type	Power [kW]	Full load current $I_{1/1}$ [A]	Motor efficiency [%]			Power factor [%]			$\frac{I_{st}}{I_{1/1}}$
				$\eta_{50\%}$	$\eta_{75\%}$	$\eta_{100\%}$	Cos $\phi_{50\%}$	Cos $\phi_{75\%}$	Cos $\phi_{100\%}$	
SP 3A-6 NE	MS 4000 RE	0.75	1.84	68.1	71.6	72.8	0.69	0.79	0.84	4.9
SP 3A-9 NE	MS 4000 RE	0.75	1.84	68.1	71.6	72.8	0.69	0.79	0.84	4.9
SP 3A-12 NE	MS 4000 RE	0.75	1.84	68.1	71.6	72.8	0.69	0.79	0.84	4.9
SP 3A-15 NE	MS 4000 RE	1.1	2.75	70.3	74.0	74.4	0.62	0.74	0.82	5.1
SP 3A-18 NE	MS 4000 RE	1.1	2.75	70.3	74.0	74.4	0.62	0.74	0.82	5.1
SP 3A-22 NE	MS 4000 RE	1.5	4.00	69.1	72.7	73.7	0.55	0.69	0.78	4.3
SP 3A-25 NE	MS 4000 RE	1.5	4.00	69.1	72.7	73.7	0.55	0.69	0.78	4.3
SP 3A-29 NE	MS 4000 RE	2.2	6.05	67.9	73.1	74.5	0.49	0.63	0.74	4.5

Electrical data

1 x 230 V, 50 Hz

Motor type	Power [kW]	Full load current $I_{1/1}$ [A]	Motor efficiency [%]			Power factor [%]			$\frac{I_{st}}{I_{1/1}}$	Control box for 3-wire motors
			$\eta_{50\%}$	$\eta_{75\%}$	$\eta_{100\%}$	Cos $\phi_{50\%}$	Cos $\phi_{75\%}$	Cos $\phi_{100\%}$		
MS 4000 RE	2.2	14.0	67.0	73.0	75.0	0.91	0.94	0.96	4.4	SA-SPM 3

Performance curves

Submersible pumps
SP 5A-NE

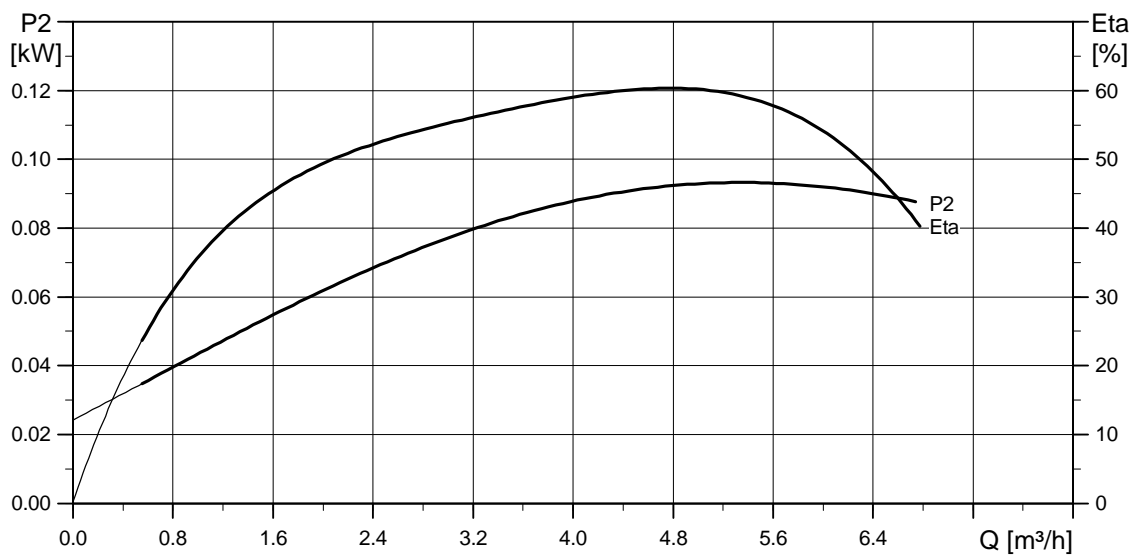
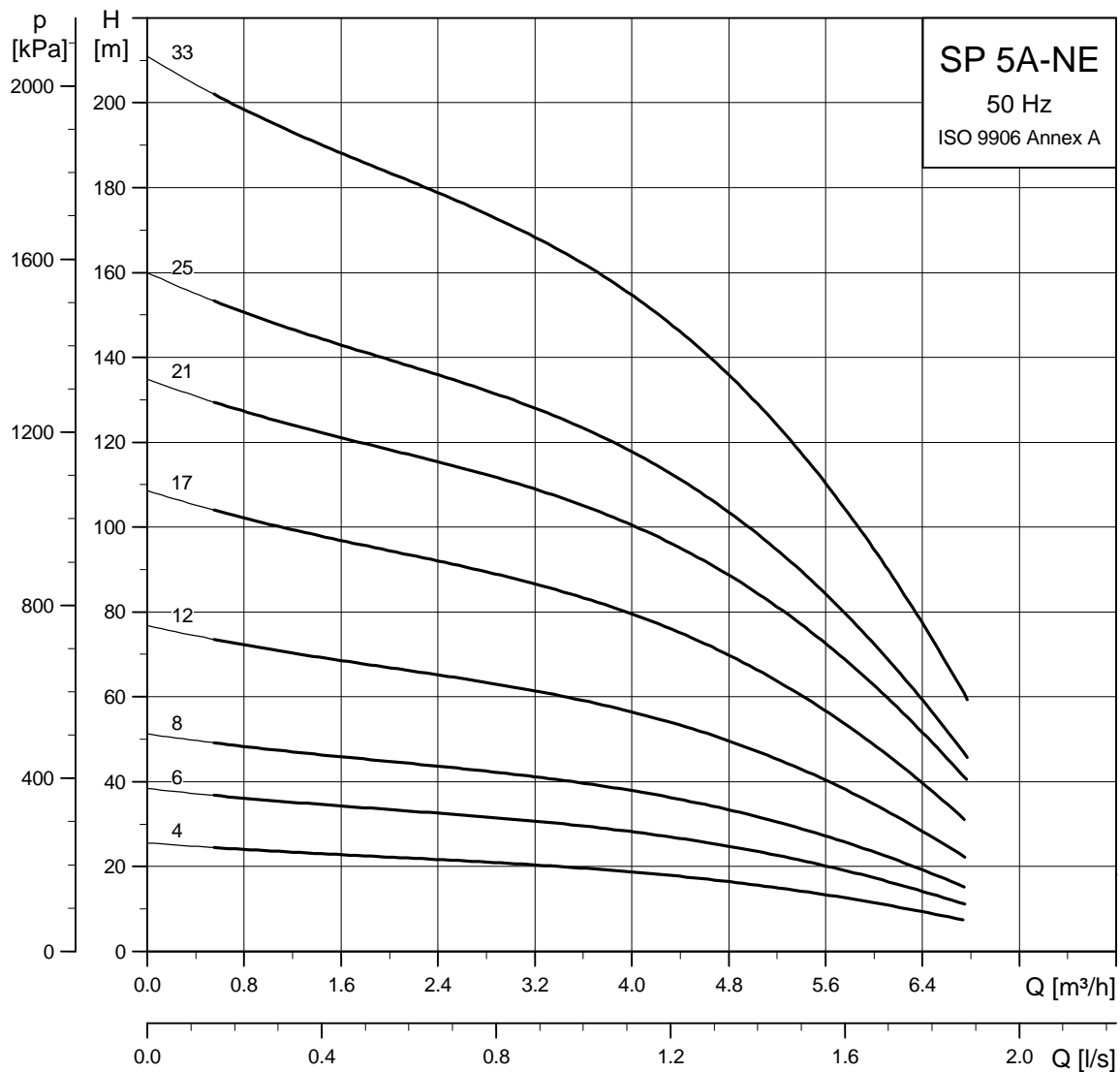

TM01 3499 2500

Dimensions and weights

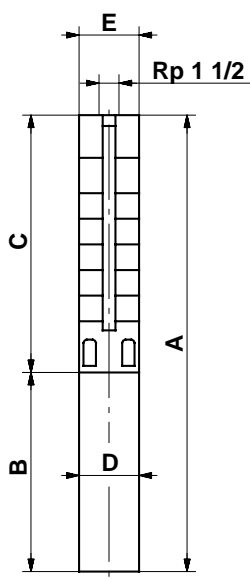

TM00 0956 1196

E = Maximum diameter of pump, inclusive of cable guard and motor.

Pump type	Motor			Dimensions [mm]						Net weights [kg]	
	Type	Power [kW]	C	B		A		D	E	Net weights [kg]	
				1x230 V	3x400 V	1x230 V	3x400 V			1x230 V	3x400 V
SP 5A-4 NE	MS 4000 RE	2.2	284	573		857	95	101	25		
SP 5A-4 NE	MS 4000 RE	0.75	284		398	682	95	101		17	
SP 5A-6 NE	MS 4000 RE	2.2	326	573		899	95	101	26		
SP 5A-6 NE	MS 4000 RE	0.75	326		398	724	95	101		18	
SP 5A-8 NE	MS 4000 RE	2.2	368	573		941	95	101	27		
SP 5A-8 NE	MS 4000 RE	0.75	368		398	766	95	101		19	
SP 5A-12 NE	MS 4000 RE	2.2	452	573		1025	95	101	28		
SP 5A-12 NE	MS 4000 RE	1.1	452		413	865	95	101		21	
SP 5A-17 NE	MS 4000 RE	2.2	557	573		1130	95	101	29		
SP 5A-17 NE	MS 4000 RE	1.5	557		413	970	95	101		22	
SP 5A-21 NE	MS 4000 RE	2.2	641	573	453	1214	1094	95	101	30	25
SP 5A-25 NE	MS 4000 RE	2.2	725	573	453	1298	1178	95	101	32	27
SP 5A-33 NE	MS 4000 RE	3.0	893		493	1386	95	101		30	

Electrical data

3 x 400 V, 50 Hz

Pump type	Motor type	Power [kW]	Full load current $I_{1/1}$ [A]	Motor efficiency [%]			Power factor [%]			$\frac{I_{st}}{I_{1/1}}$
				$\eta_{50\%}$	$\eta_{75\%}$	$\eta_{100\%}$	Cos $\phi_{50\%}$	Cos $\phi_{75\%}$	Cos $\phi_{100\%}$	
SP 5A-4 NE	MS 4000 RE	0.75	1.84	68.1	71.6	72.8	0.69	0.79	0.84	4.9
SP 5A-6 NE	MS 4000 RE	0.75	1.84	68.1	71.6	72.8	0.69	0.79	0.84	4.9
SP 5A-8 NE	MS 4000 RE	0.75	1.84	68.1	71.6	72.8	0.69	0.79	0.84	4.9
SP 5A-12 NE	MS 4000 RE	1.1	2.75	70.3	74.0	74.4	0.62	0.74	0.82	5.1
SP 5A-17 NE	MS 4000 RE	1.5	4.00	69.1	72.7	73.7	0.55	0.69	0.78	4.3
SP 5A-21 NE	MS 4000 RE	2.2	6.05	67.9	73.1	74.5	0.49	0.63	0.74	4.5
SP 5A-25 NE	MS 4000 RE	2.2	6.05	67.9	73.1	74.5	0.49	0.63	0.74	4.5
SP 5A-33 NE	MS 4000 RE	3.0	7.85	71.5	74.5	75.2	0.53	0.67	0.77	4.5

Electrical data

1 x 230 V, 50 Hz

Motor type	Power [kW]	Full load current $I_{1/1}$ [A]	Motor efficiency [%]			Power factor [%]			$\frac{I_{st}}{I_{1/1}}$	Control box for 3-wire motors
			$\eta_{50\%}$	$\eta_{75\%}$	$\eta_{100\%}$	Cos $\phi_{50\%}$	Cos $\phi_{75\%}$	Cos $\phi_{100\%}$		
MS 4000 (RE)	2.2	14.0	67.0	73.0	75.0	0.91	0.94	0.96	4.4	SA-SPM 3

Performance curves

Submersible pumps
SP 8A-NE

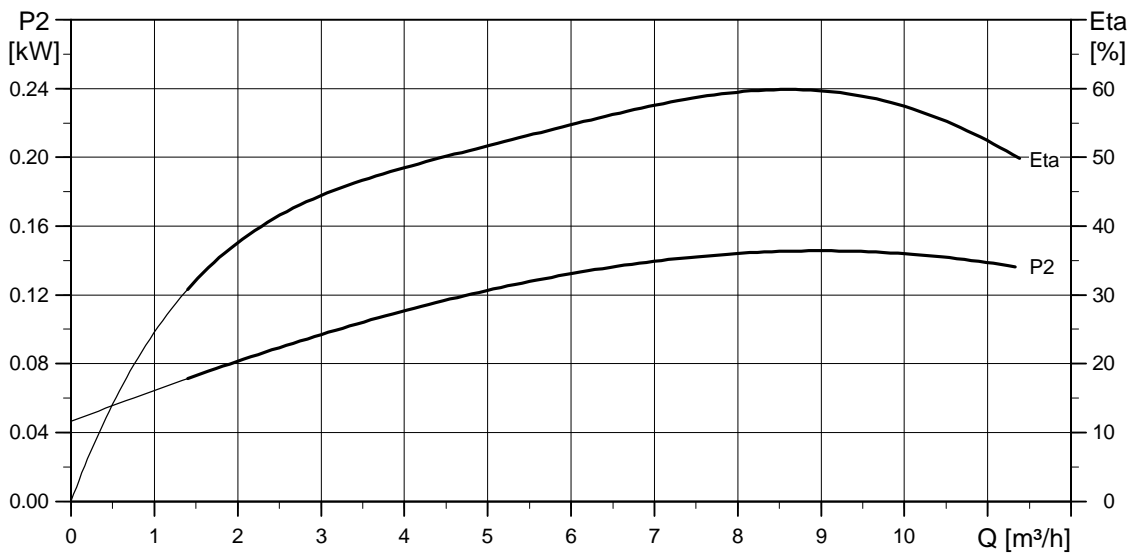
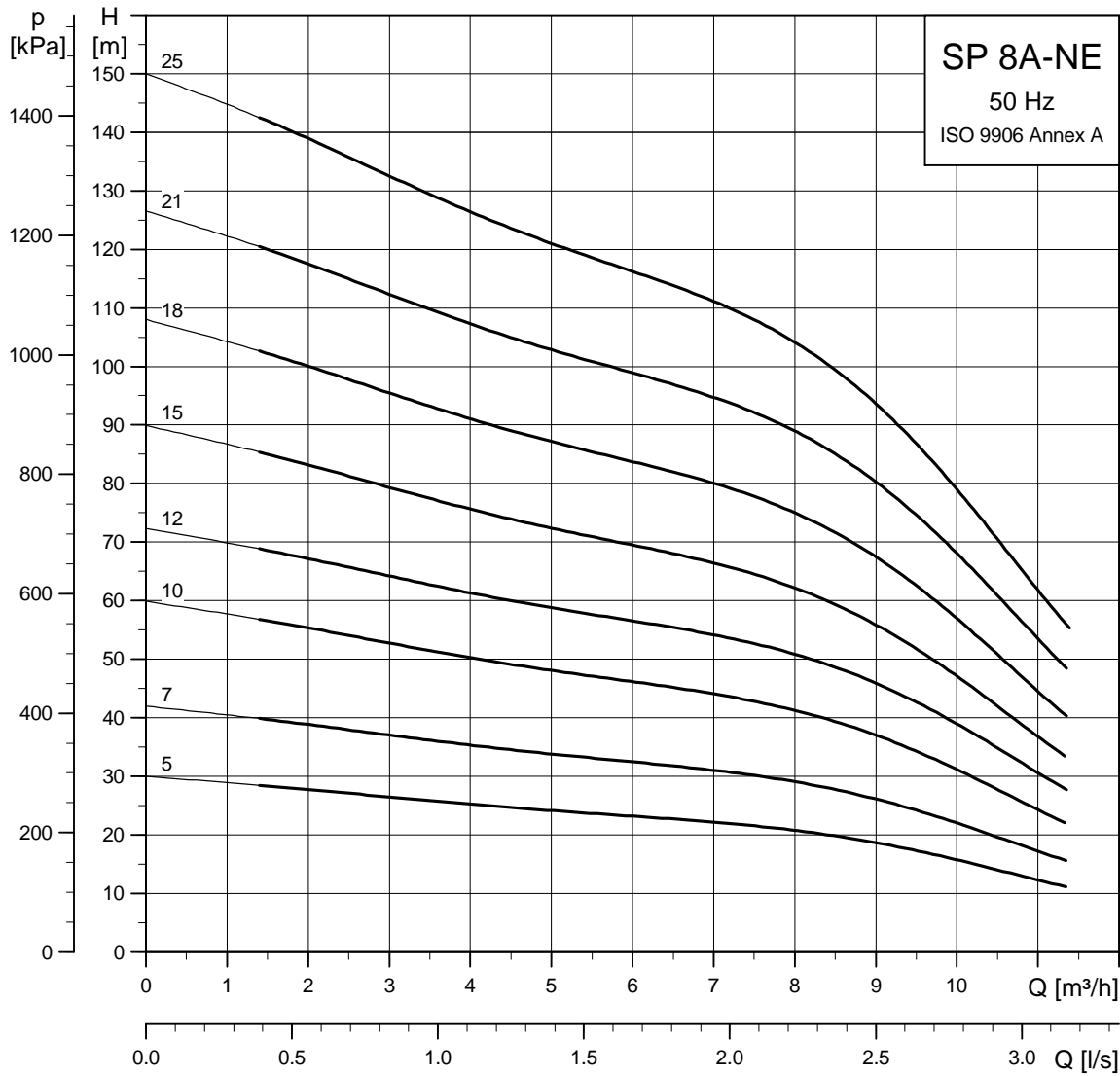

TM01 3500 2500

Dimensions and weights

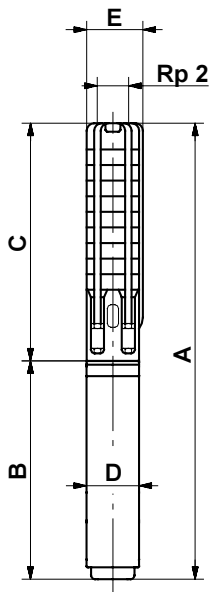

TM00 0957 1196

Pump type	Motor			Dimensions [mm]						Net weights [kg]	
	Type	Power [kW]	C	B		A		D	E	1x230 V	3x400 V
				1x230 V	3x400 V	1x230 V	3x400 V				
SP 8A-5 NE	MS 4000 RE	2.2	409	573		982		95	101	27	
SP 8A-5 NE	MS 4000 RE	0.75	409		398		807	95	101		19
SP 8A-7 NE	MS 4000 RE	2.2	493	573		1066		95	101	28	
SP 8A-7 NE	MS 4000 RE	1.1	493		413		906	95	101		21
SP 8A-10 NE	MS 4000 RE	2.2	619	573		1192		95	101	30	
SP 8A-10 NE	MS 4000 RE	1.5	619		413		1032	95	101		23
SP 8A-12 NE	MS 4000 RE	2.2	703	573	453	1276	1156	95	101	30	25
SP 8A-15 NE	MS 4000 RE	2.2	829	573	453	1402	1282	95	101	32	27
SP 8A-18 NE	MS 4000 RE	3.0	955		493		1448	95	101		29
SP 8A-21 NE	MS 4000 RE	4.0	1081		573		1654	95	101		35
SP 8A-25 NE	MS 4000 RE	4.0	1249		573		1822	95	101		37

E = Maximum diameter of pump, inclusive of cable guard and motor.

Electrical data

3 x 400 V, 50 Hz

Pump type	Motor type	Power [kW]	Full load current $I_{1/1}$ [A]	Motor efficiency [%]			Power factor [%]			$\frac{I_{st}}{I_{1/1}}$
				$\eta_{50\%}$	$\eta_{75\%}$	$\eta_{100\%}$	Cos $\phi_{50\%}$	Cos $\phi_{75\%}$	Cos $\phi_{100\%}$	
SP 8A-5 NE	MS 4000 RE	0.75	1.84	68.1	71.6	72.8	0.69	0.79	0.84	4.9
SP 8A-7 NE	MS 4000 RE	1.1	2.75	70.3	74.0	74.4	0.62	0.74	0.82	5.1
SP 8A-10 NE	MS 4000 RE	1.5	4.00	69.1	72.7	73.7	0.55	0.69	0.78	4.3
SP 8A-12 NE	MS 4000 RE	2.2	6.05	67.9	73.1	74.5	0.49	0.63	0.74	4.5
SP 8A-15 NE	MS 4000 RE	2.2	6.05	67.9	73.1	74.5	0.49	0.63	0.74	4.5
SP 8A-18 NE	MS 4000 RE	3.0	7.85	71.5	74.5	75.2	0.53	0.67	0.77	4.5
SP 8A-21 NE	MS 4000 RE	4.0	9.60	77.3	78.4	78.0	0.57	0.71	0.80	4.8
SP 8A-25 NE	MS 4000 RE	4.0	9.60	77.3	78.4	78.0	0.57	0.71	0.80	4.8

Electrical data

1 x 230 V, 50 Hz

Motor type	Power [kW]	Full load current $I_{1/1}$ [A]	Motor efficiency [%]			Power factor [%]			$\frac{I_{st}}{I_{1/1}}$	Control box for 3-wire motors
			$\eta_{50\%}$	$\eta_{75\%}$	$\eta_{100\%}$	Cos $\phi_{50\%}$	Cos $\phi_{75\%}$	Cos $\phi_{100\%}$		
MS 4000 (RE)	2.2	14.0	67.0	73.0	75.0	0.91	0.94	0.96	4.4	SA-SPM 3

Performance curves

Submersible pumps
SP 17-NE

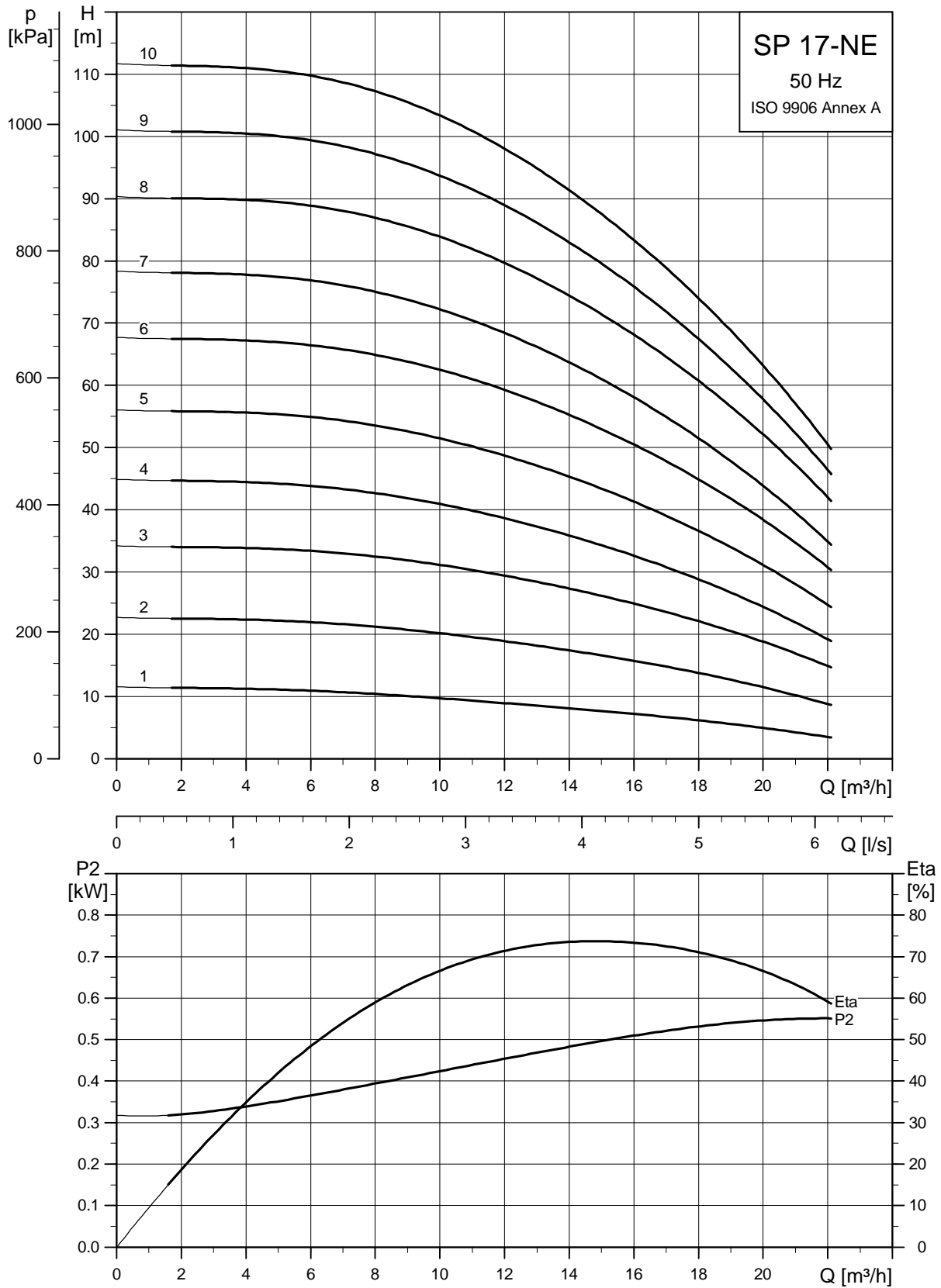

TM01 3501 2500

Dimensions and weights

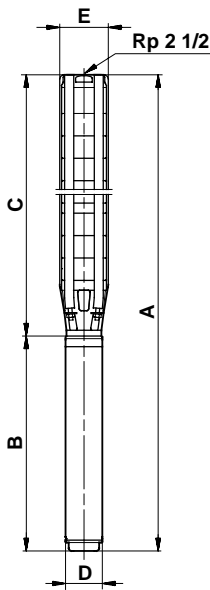

TM027450 3503

E = Maximum diameter of pump, inclusive of cable guard and motor.

Pump type	Motor			Dimensions [mm]						Net weights [kg]	
	Type	Power [kW]	C	B		A		D	E	1x230 V	3x400 V
				1x230 V	3x400 V	1x230 V	3x400 V				
SP 17-1 NE	MS 4000 RE	2.2	314	573		887	95	131	25		
SP 17-1 NE	MS 4000 RE	0.75	314		398		712	95	131	17	
SP 17-2 NE	MS 4000 RE	2.2	374	573		947	95	131	27		
SP 17-2 NE	MS 4000 RE	1.1	374		413		787	95	131	20	
SP 17-3 NE	MS 4000 RE	2.2	435	573	453	1008	888	95	131	28	
SP 17-4 NE	MS 4000 RE	2.2	495	573	453	1068	948	95	131	29	
SP 17-5 NE	MS 4000 RE	3.0	556		493		1049	95	131	26	
SP 17-6 NE	MS 4000 RE	4.0	616		573		1189	95	131	31	
SP 17-7 NE	MS 4000 RE	4.0	677		573		1250	95	131	33	
SP 17-8 NE	MS 4000 RE	5.5	737		673		1410	95	131	39	
SP 17-9 NE	MS 4000 RE	5.5	798		673		1471	95	131	40	
SP 17-10 NE	MS 4000 RE	5.5	858		673		1531	95	131	41	

Electrical data

3 x 400 V, 50 Hz

Pump type	Motor type	Power [kW]	Full load current $I_{1/1}$ [A]	Motor efficiency [%]			Power factor [%]			$\frac{I_{st}}{I_{1/1}}$
				$\eta_{50\%}$	$\eta_{75\%}$	$\eta_{100\%}$	Cos $\varphi_{50\%}$	Cos $\varphi_{75\%}$	Cos $\varphi_{100\%}$	
SP 17-1 NE	MS 4000 RE	0.75	1.80	68.1	71.6	72.8	0.69	0.79	0.84	4.9
SP 17-2 NE	MS 4000 RE	1.1	2.75	70.3	74.0	74.4	0.62	0.74	0.82	5.1
SP 17-3 NE	MS 4000 RE	2.2	6.05	67.9	73.1	74.5	0.49	0.63	0.74	4.5
SP 17-4 NE	MS 4000 RE	2.2	6.05	67.9	73.1	74.5	0.49	0.63	0.74	4.5
SP 17-5 NE	MS 4000 RE	3.0	7.85	71.5	74.5	75.2	0.53	0.67	0.77	4.5
SP 17-6 NE	MS 4000 RE	4.0	9.60	77.3	78.4	78.0	0.57	0.71	0.80	4.8
SP 17-7 NE	MS 4000 RE	4.0	9.60	77.3	78.4	78.0	0.57	0.71	0.80	4.8
SP 17-8 NE	MS 4000 RE	5.5	13.0	78.5	80.1	79.8	0.57	0.72	0.81	4.9
SP 17-9 NE	MS 4000 RE	5.5	13.0	78.5	80.1	79.8	0.57	0.72	0.81	4.9
SP 17-10 NE	MS 4000 RE	5.5	13.0	78.5	80.1	79.8	0.57	0.72	0.81	4.9

Electrical data

1 x 230 V, 50 Hz

Motor type	Power [kW]	Full load current $I_{1/1}$ [A]	Motor efficiency [%]			Power factor [%]			$\frac{I_{st}}{I_{1/1}}$	Control box for 3-wire motors
			$\eta_{50\%}$	$\eta_{75\%}$	$\eta_{100\%}$	Cos $\varphi_{50\%}$	Cos $\varphi_{75\%}$	Cos $\varphi_{100\%}$		
MS 4000 (RE)	2.2	14.0	67.0	73.0	75.0	0.91	0.94	0.96	4.4	SA-SPM 3

Material specification (pump)

Pos.	Component	Material	DIN W.-Nr.
1	Valve casing	Stainless steel	1.4401
2	Top bearing	FKM	
3	Chamber	Stainless steel	1.4401
4	Intermediate bearing	FKM	
5	Impeller	Stainless steel	1.4401
6	Suction interconnector	Stainless steel	1.4401
7	Shaft	Stainless steel	1.4401
8	Strap	Stainless steel	1.4401

Material specification (motor)

Pos.	Component	Material	DIN W.-Nr.
9	Radial bearing	Ceramic/ tungsten carbid	
10	Thrust bearings	Carbon/ceramic	
11	Shaft end	Stainless steel	1.4462
12	Stator housing	Stainless steel	1.4539
13	End shield	Stainless steel	1.4539
	O-rings	FKM	

SP 8A-NE

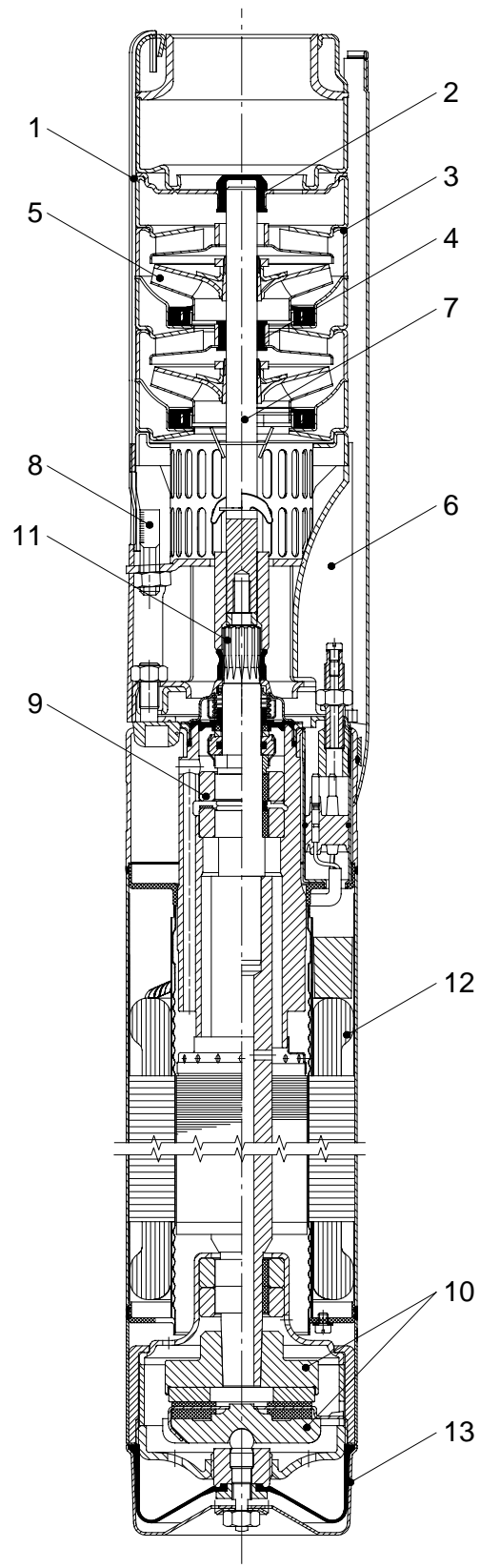

TM01 9176 1300

CU 3

The CU 3 control unit is an electronic motor starter for monitoring and protecting installations with rated voltages of 200 - 575 V, 50 - 60 Hz, and a maximum power consumption of 400 A.

The CU 3 monitors the following parameters:

- System insulation resistance to earth before start.
- Motor temperature.
- Motor current consumption and current unbalance.
- Supply voltage.
- Phase sequence.

The CU 3 protects against:

- Dry running.
- Incipient motor defect.
- Too high motor temperature.
- Motor burnout.

As standard, the CU 3 incorporates:

- Time relay for star-delta starting and autotransformer starting.
- Relay output for external fault indication.

In addition, CU 3 can be expanded to offer the following functions:

- **Remote control R100:** Wireless infra-red remote control by means of the R100. This function enables the user to change factory settings and to monitor the installation by calling up actual operating data, e.g. current consumption, supply voltage and operating hours.
- **External sensors SM 100:** Reception of data from external sensors by means of an SM 100 sensor module and control according to the data received, e.g. flow rate, pressure, water level and conductivity.
- **Communication module:** Monitoring and communication via a data bus (GENIbus), a modem or radio, e.g. PC-based control/monitoring.

Technical data

Enclosure class:	IP 20.
Ambient temp.:	-20°C to +60°C.
Relative humidity:	99%.
Voltage variation:	-25/+15% of nominal voltage.
Frequency:	45-65 Hz.
Max. back-up fuse:	10 A.
Output relays:	Max. 415 V, 3 A, AC 1.
Approvals:	The CU 3 complies with: VDE, DEMKO, EN, UL and CSA.
Marking:	CE.

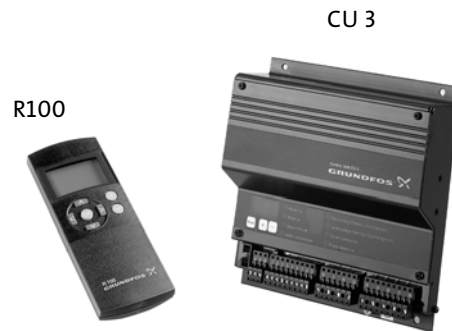

GR0244 - GR1911

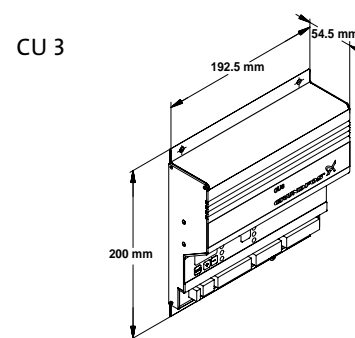

TM00 7308 1102

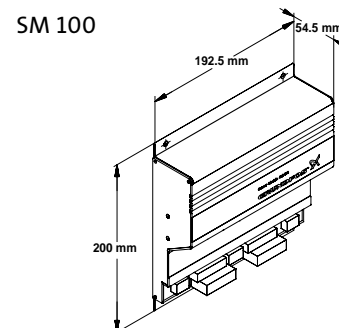

TM01 4020 1102

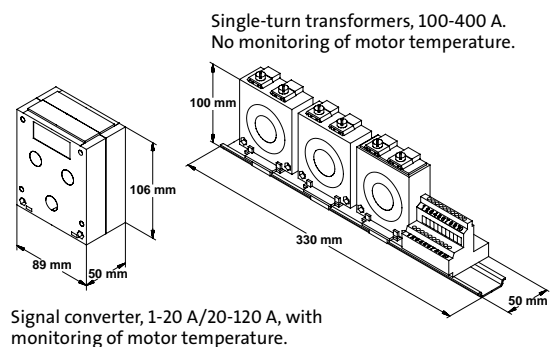

Signal converter, 1-20 A/20-120 A, with monitoring of motor temperature.

Single-turn transformers, 100-400 A.
No monitoring of motor temperature.

TM00 7866 1096

Control functions

This table describes the protection provided by CU 3.

Control parameters	Function	Problem	Advantages
Ground failure	<p>Insulation resistance is measured only when the motor is not operating. A high-impedance voltage is applied to the motor leads and leakage to ground is measured.</p> <p>If the factory-set value is higher than the one measured, the motor cannot be started.</p>	<ul style="list-style-type: none"> Damaged or decomposed insulation in motor, cable or cable joint. 	<ul style="list-style-type: none"> Possibility of indication of failure/of motor, cable and cable joint, service indication.
Temperature	<p>The actual motor temperature is measured by means of the built-in Tempcon temperature transmitter and a signal is sent to CU 3 via the phase leads. CU 3 compared the measured temperature with the factory-set value.</p>	<ul style="list-style-type: none"> Overload, frequent starts/stops, operation against blocked discharge pipe, insufficient flow velocity past the motor. 	<ul style="list-style-type: none"> Longer motor life, safe operating conditions, service indication.
Overvoltage/undervoltage	<p>If the factory-set values are exceeded, a fault indication is given. If the CU 3 receives a temperature signal, the voltage is no longer monitored, but the motor will continue to run.</p> <p>Therefore, the motor and consequently the pump operation will only be affected by voltage variations critical to the life of the motor.</p> <p>If there is no temperature signal, the motor will be stopped in case of overvoltage/undervoltage.</p>	<ul style="list-style-type: none"> The installation is close to a transformer, the mains do not absorb load variations. 	<ul style="list-style-type: none"> Important installation parameter, possibility of improving operating conditions.
Overload	<p>The motor power input is measured on each of the three phases. The registered power input is an average of these three values.</p> <p>If the factory-set value is exceeded, the motor will stop.</p>	<ul style="list-style-type: none"> Incorrect dimensioning of pump/motor, voltage supply failure, defective cable, blocking, wear or corrosion. 	<ul style="list-style-type: none"> Longer motor life, safe operating conditions, service indication.
Dry running	<p>The motor power input is measured on each of the three phases. The registered power input is an average of these three values.</p> <p>If the average value is lower than the factory-set value, the motor will stop.</p>	<ul style="list-style-type: none"> Pump exposed to dry running or underload, for example caused by wear. 	<ul style="list-style-type: none"> Traditional dry-running protection is no longer necessary, no extra cables.
Current unbalance	<p>The motor power input is measured on each of the three phases.</p>	<ul style="list-style-type: none"> Mains load is uneven, incipient motor defect, phase voltages diverging. 	<ul style="list-style-type: none"> Motor protection against overload, service indication.
Phase sequence	<p>CU 3 and motor are installed so that the phase sequence corresponds to correct direction of rotation.</p> <p>CU 3 monitors changes in the phase sequences.</p>	<p>Two phases are wrongly connected.</p>	<p>Ensures correct pump performance.</p>

Features and benefits

Selecting the right pump

The Grundfos CU 3 control unit and a flowmeter provide for a constant monitoring of energy consumption and performance of the pump thus making it possible to ensure that the right pump is selected for the application in question.

The CU 3 control unit makes it possible to choose the borehole(s) to be in operation which offer(s) the lowest operating costs.

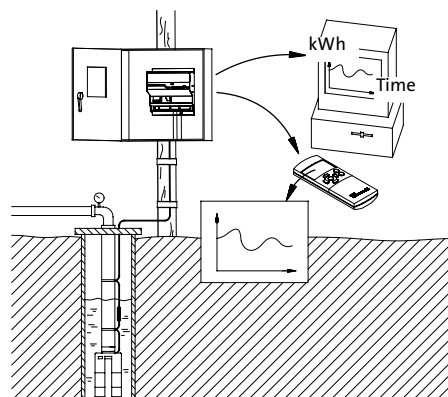

TM00 7296 1096

Choosing the right time for service

The constant monitoring by the CU 3 control unit makes it possible to service the pump, i.e. clean it and replace wear parts, at the best possible time.

Today service and maintenance work is often carried out at regular intervals or when actual downtime occurs. Both are unlikely to result in an optimum energy-efficient operation.

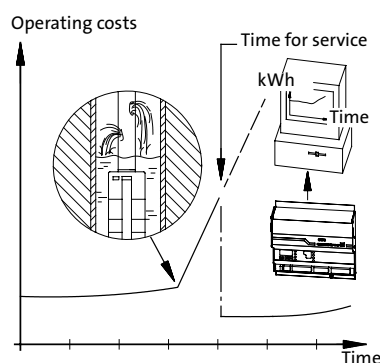

TM00 7297 1096

Avoiding overpumping

Using the Grundfos CU 3 control unit and a water level sensor makes it possible to carry out test pumping of each borehole by measuring the water table level and the volume of water which is pumped. The purpose is to ensure pumping of only the water naturally running to the borehole. As a result operations will provide for optimum efficiency. Consequently, the lives of both borehole and pump will increase, since both water aeration and the risk of ingress of aggressive water are reduced.

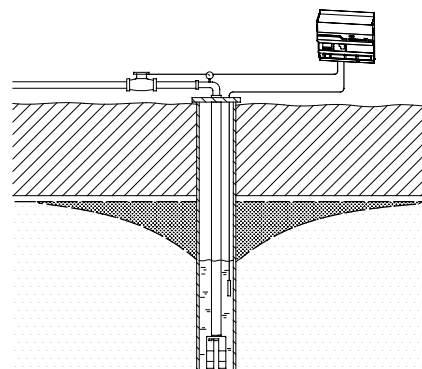

TM00 7298 1096

Reducing costs of water treatment

By minimizing the risk of overpumping and thus the pumping of impure groundwater, the costs of water treatment can be reduced to a minimum.

Using the Grundfos CU 3 control unit and a sensor makes it possible to measure the water conductivity in each borehole. This allows selection of the borehole (or boreholes) which supplies the best water quality at any time.

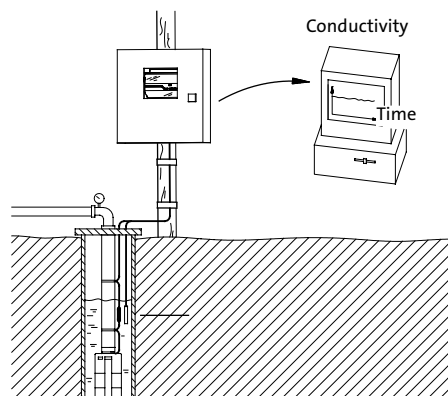

TM00 7299 1096

Motor protection via CU 3

Monitoring parameters (Diodes)

- Power on
- Motor on
- Motor temperature
- Ground failure
- Overload/dry running
- Overvoltage/undervoltage
- Current unbalance
- Direction of rotation

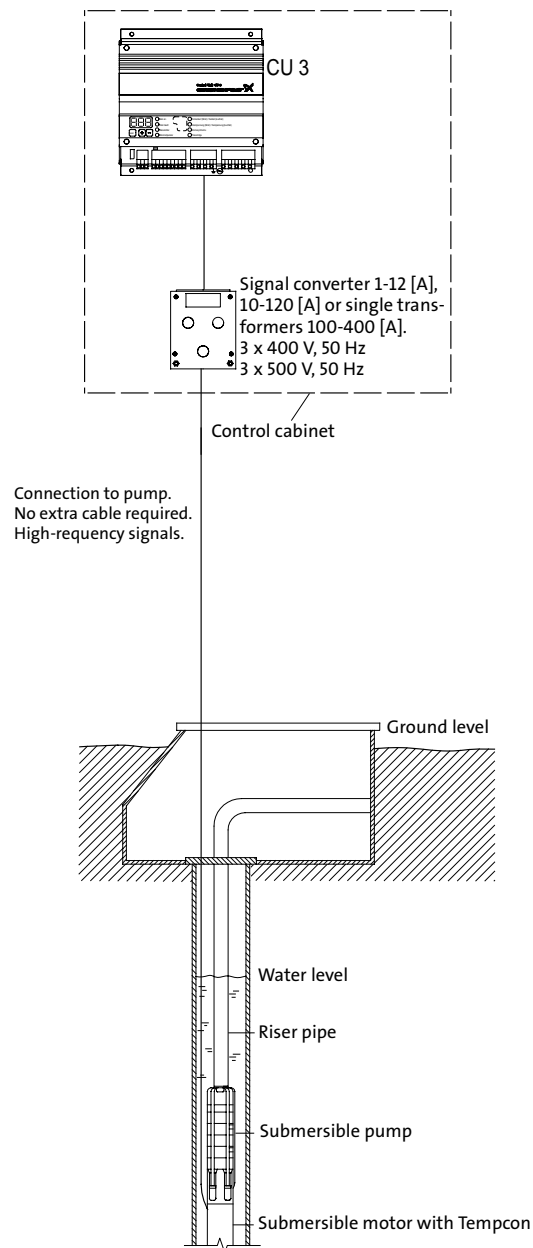

TM007977 1702

CU 3 control unit with R100 remote control and printer

Monitoring parameters (Diodes)

- Power on
- Motor on
- Motor temperature
- Ground failure
- Overload/dry running
- Overvoltage/undervoltage
- Current unbalance
- Direction of rotation

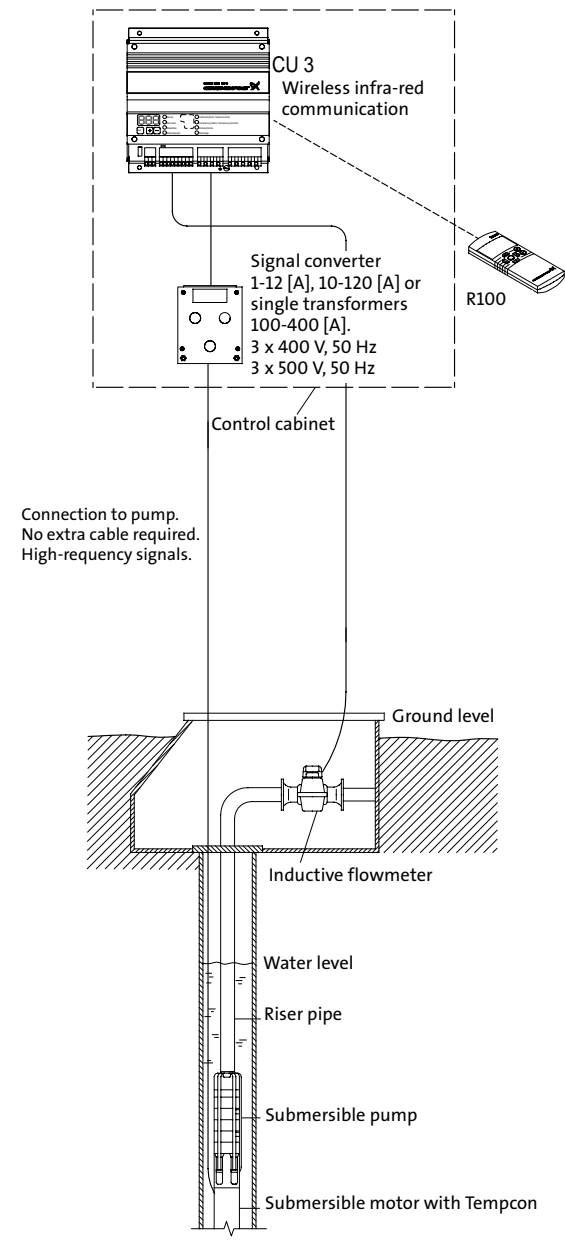

TM007978 1702

R100 menus for CU 3

0. General

1. Operation

- 1.1 Warning and stop indication
- 1.2 Indication of automatically reset fault indications
Possibility of start and stop.

2. Status

Indication of:

- 2.1 Motor temperature
- 2.2 Current and voltage values
- 2.3 Average supply voltage
- 2.4 Average input current of the three phases
- 2.5 Actual current unbalance
- 2.6 Actual insulation resistance to earth
- 2.7 Phase sequence and frequency
- 2.8 Actual power input and total power consumption
- 2.9 Accumulated number of operating hours
- 2.10 Value measured by an external sensor
- 2.11 Energy consumption per m³ pumped liquid
- 2.12 Actual flow
- 2.13 Accumulated flow.

The R100 offers a number of setting possibilities:

3. Limits

Indication and setting of:

- 3.1 Motor temperature
- 3.2 Current stop limits
- 3.3 Current warning limits
- 3.4 Voltage variations
- 3.5 Insulation resistance
- 3.6 Current unbalance
- 3.7 Stop for external sensor
- 3.8 Warning limits for external sensor.

4. Installation

Setting possibilities:

- 4.1 Automatic or manual resetting of fault indications
- 4.2 Release time for fault indications
- 4.3 Star connection time for star-delta or auto-transformer starting
- 4.4 Starting delay when first started, e.g. after supply failure
- 4.5 Minimum start cycle time
- 4.6 On/off of groundwater lowering function
- 4.7 Run/stop times for groundwater lowering
- 4.8 Electronic numbering of CU 3 units
- 4.9 On/off of power and temperature measuring function
- 4.10 External sensor type
On/off of external analog sensor with or without zero offset
Maximum value of external analog sensor
- 4.11 Groundwater lowering by means of level sensors
Filling and emptying function
- 4.12 On/off of external digital sensor.

Status report

All settings and measured values can be transferred to a portable printer via wireless infra-red communication and be printed in a status report.

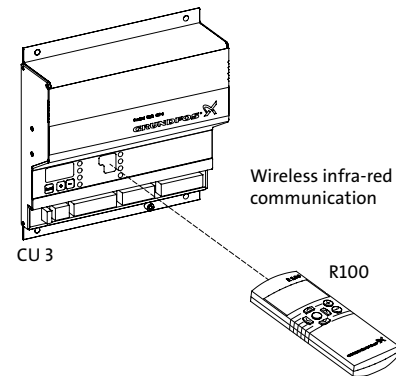

TM00 7981.1702

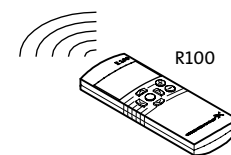
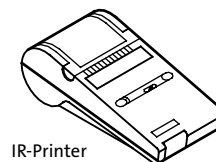

TM00 7982.1302

R100 menu structure for the CU 3

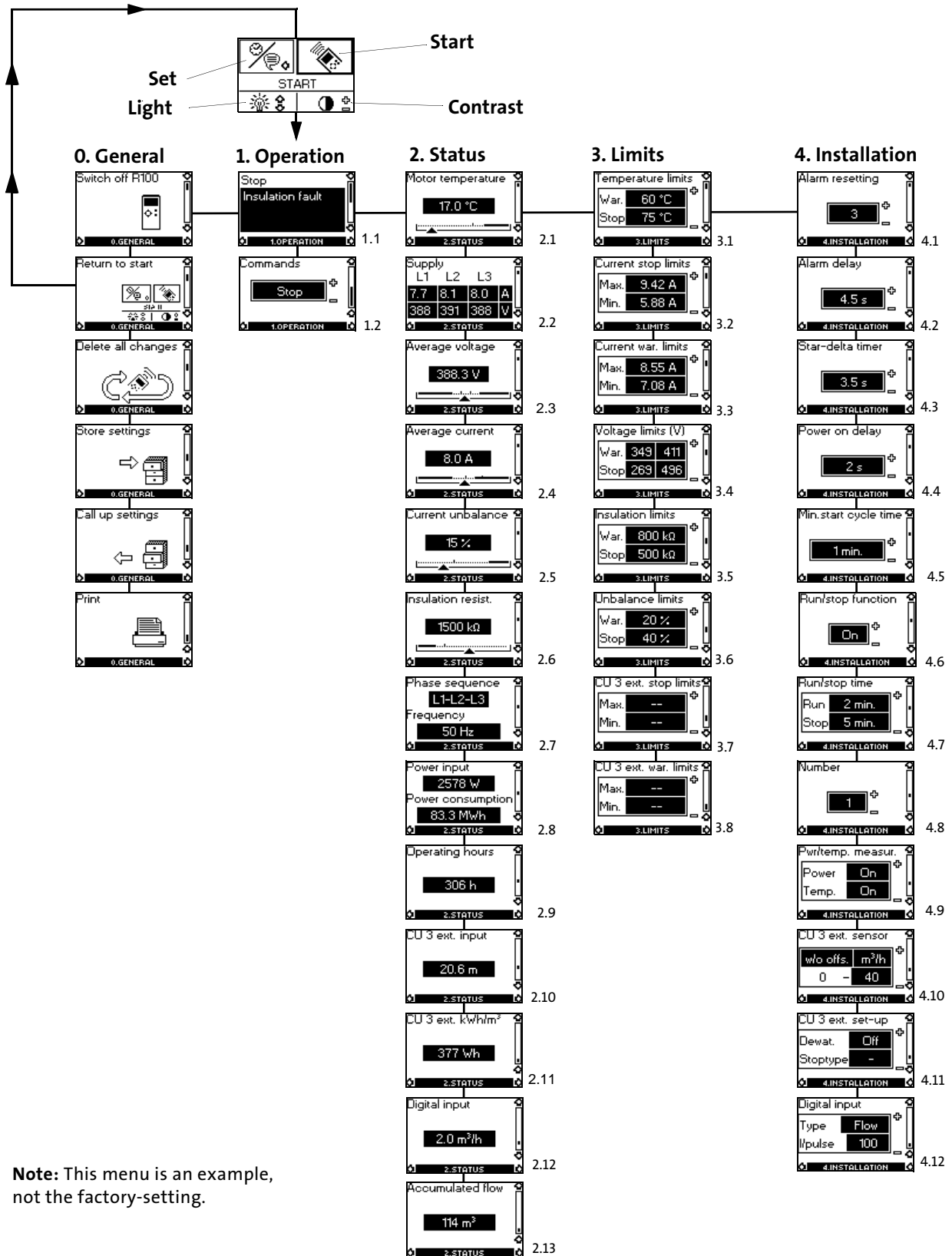

Complete borehole monitoring system with CU 3 and SM 100

Monitoring parameters (diodes)

- Power on
- Motor on
- Motor temperature
- Ground failure
- Overload/dry running
- Overvoltage/undervoltage
- Current unbalance
- Direction of rotation

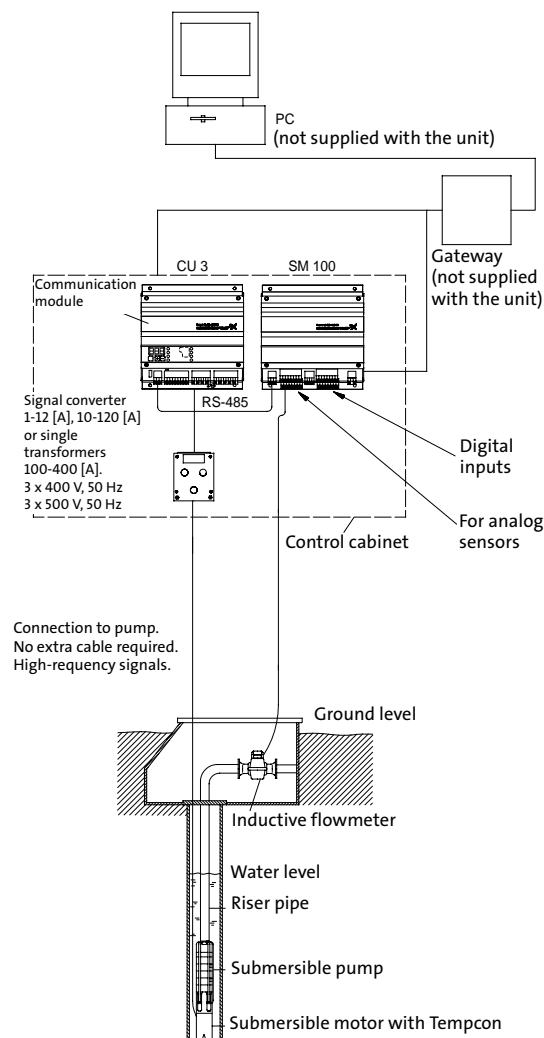

TM00 7979 1702

SM 100

The SM 100 sensor module can be connected to eight analog sensors and have eight digital inputs for sensors, monitoring e.g.,

- pH value
- conductivity
- O₂
- pressure
- etc.

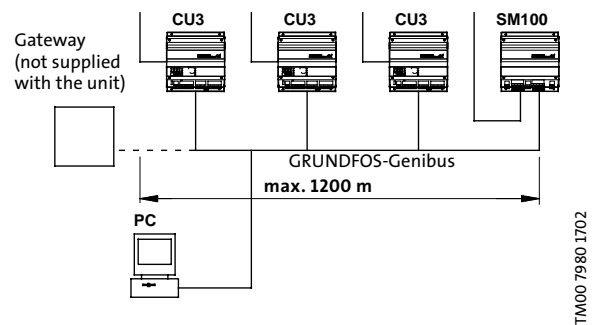

Maximum connection to the GENibus:

- 28 CU 3 units or
- 14 CU 3 units and 14 SM 100 units or
- 27 CU 3 and 1 SM 100.

Product numbers

Product number	CU 3 - 3 x 400 V		
	Current range for signal converter [A]		
	1-12	10-120	100-400
62500293	•		
62500294		•	
62500295			•

CU 3 expansion possibilities

Product	Range	Product number
SM 100 sensor module	3 x 400 [V]	00626191
RS 485 communication module	-	00626159
R100 remote control	-	00625333
HP printer for R100	-	00620480
Signal converter	1 - 12 [A]	00620497
	10 - 120 [A]	00620498
	100 - 400 [A] ★	00626148

★ Single-turn transformers

G100 - Gateway for communication with Grundfos products

The G100 Grundfos offers optimum integration of Grundfos products into main control and monitoring systems.

The G100 product meets future requirements regarding optimum pump operation, e.g., reliability and low operating costs.

For further information about G100, please see the G100 data sheet.



GR5940

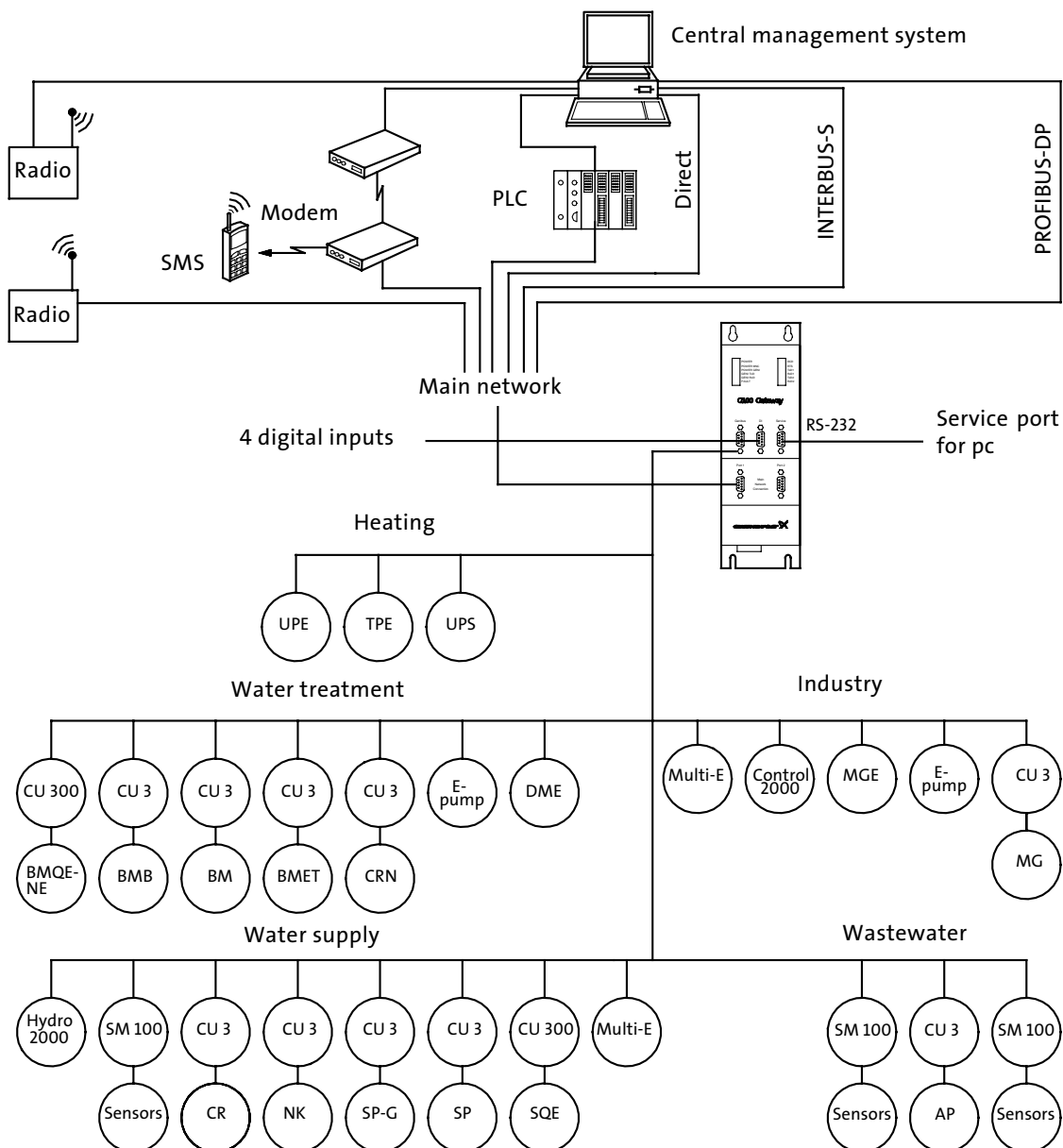

TM01.1804.1102

Product description

The G100 Gateway enables communication of operating data, such as measured values, setpoints, etc., between Grundfos products with GENIbus interface and a main network for control and monitoring.

As indicated in the illustration on page 72, the G100 is suitable for use in applications such as water supply, water treatment, wastewater, building automation and industry.

Common to above applications is that downtime is usually costly, and extra investments are therefore often made to achieve maximum reliability by monitoring selected operating variables.

The day-to-day operation, such as starting and stopping of pumps, changing of setpoints, etc., can also be effected from the main system by communication with the G100. In addition, the G100 can be set up to send event-controlled status indications such as alarms via the SMS to mobile phones, and to make automatic alarm call-backs to a central management system.

Data logging

Besides the possibility of data communication, the G100 also offers logging of up to 350,000 time-stamped data. Subsequently, the logged data can be transmitted to the main system or a PC for further analysis in a spreadsheet or similar program.

For the data logging, the "PC Tool G100 Data Log" software tool is used. The tool is part of the PC Tool G100 package, which must be ordered separately.

Other features

- Four digital inputs.
- Stop of all pumps in case of failing communication with the management system (optional).
- Access code for modem communication (optional).
- Alarm log.

Installation

Installation of the G100 is effected by the system integrator. The G100 is connected to the GENIbus as well as to the main network. Subsequently, all units on the GENIbus can be controlled from a central management system on the main network.

The "G100 Support Files" CD-ROM supplied with the G100 contains examples of programs to be used when the G100 is connected to the various main network systems. Included is also a description of the data points available in Grundfos products with GENIbus interface. The "PC Tool G100" software tool can be used for the G100 installation and use. To be ordered separately.

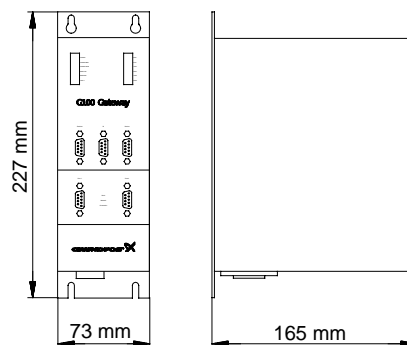

TM0106211102

Technical data

Overview of protocols

Main system	Software protocol
INTERBUS-S	PCP
PROFIBUS-DP	DP
Radio	Satt Control COMLI/Modbus
Modem	Satt Control COMLI/Modbus
PLC	Satt Control COMLI/Modbus
GSM mobile phone	SMS, UCP

Other possible connections

GENIbus RS-485: Connection of up to 32 units.

Service port
RS-232: For direct connection to a PC or via radio modem.

Digital inputs: 4.

Voltage supply: 1 x 110-240 V, 50/60 Hz

Ambient temperature: In operation: -20°C to +60°C

Enclosure class: IP 20

Weight: 1.8 kg.

Accessories

- PC Tool G100 package (to be ordered separately)
- G100 Support Files CD-ROM (supplied with product)

Product numbers

Product	Product number
G100 with Interbus-S expansion board*	96411134
G100 with Profibus-DP expansion board*	96411135
G100 with Radio/Modem/PLC-expansion board*	96411136
G100 Basic Version*	96411137
PC Tool G100 package	96415783

* Floppy disk with G100 Support Files included.

MTP 75 motor protection

Long motor life

The MTP 75 protects against too high motor temperature. This is the simple and most cost-effective means of ensuring long motor life. The customer can be confident that operating conditions are observed and is provided with an indication of when a service check should be made.

Too high motor temperature may be caused by:

- Overload
- Frequent starts/stops (hunting)
- Operation against closed valve/frozen discharge pipe
- Insufficient flow of liquid past the motor
- Pumping of too hot water
- Incrustation on the motor
- Overvoltage
- Undervoltage
- Current unbalance
- Dry running

Note: The pump is not protected if the water table is below the pump inlet. This may occur, for example, if several boreholes are located close to each other.

Application and installation

The MTP 75 can be used only for motors with built-in temperature transmitter and should be installed for instance in a control cabinet. The MTP 75 may be installed in any type of control cabinet containing a thermal relay with differential release and contactor.

The thermal relay is required for to protection against blocking or phase failure, as this will cause the temperature to rise much faster than the MTP 75 is able to register.

The MTP 75 is supplied with plug-in base for DIN rail mounting.

Operation

The motor temperature is sent as a high-frequency signal from the temperature transmitter through the motor supply cable. The MTP 75 stops the motor via the contactor if the temperature exceeds 75°C. The temperature limit is factory-set and cannot be changed.

Display:

No light: Motor stopped. No supply voltage or electrical fault at temperature measuring.

Green light: Motor running. Motor temperature OK, i.e. below 75°C.

Red light: Motor stopped. Motor temperature too high, i.e. above 75°C.

Manual resetting of the MTP 75 by pressing the reset button on the front cover or by switching off the voltage supply to the MTP 75.

No unnecessary downtime

As the MTP 75 measures only the temperature and not the parameters causing the temperature to rise, the motor and thus the pump will stop only when the motor temperature is too high.

Reliability

The MTP 75 is reliable due to its simple construction and because it requires no extra cables in the borehole.

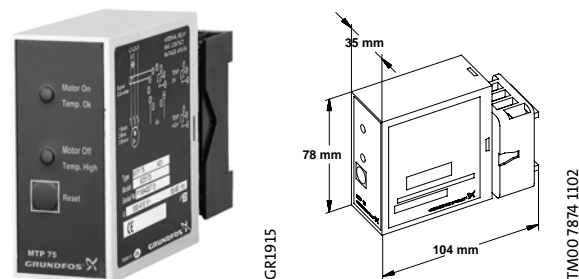

Technical data of MTP 75

Supply voltage:	2 variants: 1 x 200-240 V $\pm 10\%$, 50/60 Hz. 3 x 380-415 V $\pm 10\%$, 50/60 Hz. A transformer is required for voltages over 415 V.
Control voltage:	Contact rating: Maximum 415 V/3 A. Minimum 12 V/20 mA.
Enclosure class:	IP 20.
Operating conditions:	Min. temperature: -20°C . Max. temperature: $+60^{\circ}\text{C}$. Relative humidity: 99%.
Storage:	Min. temperature: -20°C . Max. temperature: $+60^{\circ}\text{C}$. Relative humidity: 99%.
Approvals:	Comply with the regulations of VDE and DEMKO.

Product numbers

MTP 75 without plug-in base, capacitor and signal transformer:

Voltage range [V]	Product number
1 x 200-240	00625178
3 x 380-415	00625179

MTP 75 complete with plug-in base, capacitor and signal transformer:

Voltage range [V]	Product number
1 x 200-240	00625804
3 x 380-415	00625805

SA-SPM control boxes

Application

SA-SPM 3 control boxes are used as starting units for single-phase, 3-wire motors, type MS 4000 RE with a power input of 2.2 kW.

The SA-SPM 3 incorporates a motor starter for protection of the motor against overload.

Technical data

Enclosure class:	IP 42.
Ambient temperature:	-20°C to $+60^{\circ}\text{C}$.
Relative humidity:	Maximum 95%, normal non-aggressive atmosphere.

Product numbers

SA-SPM 3 for MS 4000 RE, 2.2 kW motors.

SA-SPM 3 control box	Product number
1 x 220-230 V	82219307
1 x 240 V	82249307

Head losses in ordinary water pipes

Upper figures indicate the velocity of water in m/sec.

Lower figures indicate head loss in metres per 100 metres of straight pipes.

Quantity of water			Head losses in ordinary water pipes											
m ³ /h	Litres/min.	Litres/sec.	Nominal pipe diameter in inches and internal diameter in [mm]											
			½"	¾"	1"	1¼"	1½"	2"	2½"	3"	3½"	4"	5"	6"
			15.75	21.25	27.00	35.75	41.25	52.50	68.00	80.25	92.50	105.0	130.0	155.5
0.6	10	0.16	0.855 9.910	0.470 2.407	0.292 0.784									
0.9	15	0.25	1.282 20.11	0.705 4.862	0.438 1.570	0.249 0.416								
1.2	20	0.33	1.710 33.53	0.940 8.035	0.584 2.588	0.331 0.677	0.249 0.346							
1.5	25	0.42	2.138 49.93	1.174 11.91	0.730 3.834	0.415 1.004	0.312 0.510							
1.8	30	0.50	2.565 69.34	1.409 16.50	0.876 5.277	0.498 1.379	0.374 0.700	0.231 0.223						
2.1	35	0.58	2.993 91.54	1.644 21.75	1.022 6.949	0.581 1.811	0.436 0.914	0.269 0.291						
2.4	40	0.67		1.879 27.66	1.168 8.820	0.664 2.290	0.499 1.160	0.308 0.368						
3.0	50	0.83		2.349 41.40	1.460 13.14	0.830 3.403	0.623 1.719	0.385 0.544	0.229 0.159					
3.6	60	1.00		2.819 57.74	1.751 18.28	0.996 4.718	0.748 2.375	0.462 0.751	0.275 0.218					
4.2	70	1.12		3.288 76.49	2.043 24.18	1.162 6.231	0.873 3.132	0.539 0.988	0.321 0.287	0.231 0.131				
4.8	80	1.33		2.335 30.87	1.328 7.940	0.997 3.988	0.997 3.988	0.616 1.254	0.367 0.363	0.263 6.164				
5.4	90	1.50		2.627 38.30	1.494 9.828	1.122 4.927	0.693 1.551	0.413 0.449	0.269 0.203					
6.0	100	1.67		2.919 46.49	1.660 11.90	1.247 5.972	0.770 1.875	0.459 0.542	0.329 0.244	0.248 0.124				
7.5	125	2.08		3.649 70.41	2.075 17.93	1.558 8.967	0.962 2.802	0.574 0.809	0.412 0.365	0.310 0.185	0.241 0.101			
9.0	150	2.50			2.490 25.11	1.870 12.53	1.154 3.903	0.668 1.124	0.494 0.506	0.372 0.256	0.289 0.140			
10.5	175	2.92			2.904 33.32	2.182 16.66	1.347 5.179	0.803 1.488	0.576 0.670	0.434 0.338	0.337 0.184			
12	200	3.33			3.319 42.75	2.493 21.36	1.539 6.624	0.918 1.901	0.659 0.855	0.496 0.431	0.385 0.234	0.251 0.084		
15	250	4.17			4.149 64.86	3.117 32.32	1.924 10.03	1.147 2.860	0.823 1.282	0.620 0.646	0.481 0.350	0.314 0.126		
18	300	5.00				3.740 45.52	2.309 14.04	1.377 4.009	0.988 1.792	0.744 0.903	0.577 0.488	0.377 0.175	0.263 0.074	
24	400	6.67				4.987 78.17	3.078 24.04	1.836 6.828	1.317 3.053	0.992 1.530	0.770 0.829	0.502 0.294	0.351 0.124	
30	500	8.33					3.848 36.71	2.295 10.40	1.647 4.622	1.240 2.315	0.962 1.254	0.628 0.445	0.439 0.187	
36	600	10.0					4.618 51.84	2.753 14.62	1.976 6.505	1.488 3.261	1.155 1.757	0.753 0.623	0.526 0.260	
42	700	11.7						3.740 19.52	2.309 8.693	1.377 4.356	0.988 3.261	0.744 1.155	0.577 0.753	0.263 0.126
48	800	13.3						4.987 25.20	3.078 11.18	1.836 5.582	1.317 3.009	0.992 3.009	0.770 1.066	0.502 0.445
54	900	15.0						4.130 31.51	2.964 13.97	2.232 6.983	1.732 3.762	1.130 1.328	0.790 0.555	
60	1000	16.7						4.589 38.43	3.294 17.06	2.480 8.521	1.925 4.595	1.256 1.616	0.877 0.674	
75	1250	20.8							4.117 26.10	3.100 13.00	2.406 7.010	1.570 2.458	1.097 1.027	
90	1500	25.0							4.941 36.97	3.720 18.42	2.887 9.892	1.883 3.468	1.316 1.444	
105	1750	29.2								4.340 24.76	3.368 13.30	2.197 4.665	1.535 1.934	
120	2000	33.3								4.960 31.94	3.850 17.16	2.511 5.995	1.754 2.496	
150	2500	41.7									4.812 26.26	3.139 9.216	2.193 3.807	
180	3000	50.0										3.767 13.05	2.632 5.417	
240	4000	66.7											5.023 22.72	3.509 8.926
300	5000	83.3												4.386 14.42
90° bends, slide valves			1.0	1.0	1.1	1.2	1.3	1.4	1.5	1.6	1.6	1.7	2.0	2.5
T-pieces, non-return valves			4.0	4.0	4.0	5.0	5.0	5.0	6.0	6.0	6.0	7.0	8.0	9.0

The table is calculated in accordance with H. Lang's new formula $a = 0.02$ and for a water temperature of 10°C.

The head loss in bends, slide valves, T-pieces and non-return valves is equivalent to the metres of straight pipes stated in the last two lines of the table. To find the head loss in foot valves multiply the loss in T-pieces by two.

Head losses in plastic pipes

Upper figures indicate the velocity of water in m/sec.

Lower figures indicate head loss in metres per 100 metres of straight pipes.

Quantity of water			PELM/PEH PN 10															
m ³ /h	Litres/min.	Litres/sec.	PELM					PEH										
			25 20.4	32 26.2	40 32.6	50 40.8	63 51.4	75 61.4	90 73.6	110 90.0	125 102.2	140 114.6	160 130.8	180 147.2				
0.6	10	0.16	0.49 1.8	0.30 0.66	0.19 0.27	0.12 0.085												
0.9	15	0.25	0.76 4.0	0.46 1.14	0.3 0.6	0.19 0.18	0.12 0.63											
1.2	20	0.33	1.0 6.4	0.61 2.2	0.39 0.9	0.25 0.28	0.16 0.11											
1.5	25	0.42	1.3 10.0	0.78 3.5	0.5 1.4	0.32 0.43	0.2 0.17	0.14 0.074										
1.8	30	0.50	1.53 13.0	0.93 4.6	0.6 1.9	0.38 0.57	0.24 0.22	0.17 0.092										
2.1	35	0.58	1.77 16.0	1.08 6.0	0.69 2.0	0.44 0.70	0.28 0.27	0.2 0.12										
2.4	40	0.67	2.05 22.0	1.24 7.5	0.80 3.3	0.51 0.93	0.32 0.35	0.23 0.16	0.16 0.063									
3.0	50	0.83	2.54 37.0	1.54 11.0	0.99 4.8	0.63 1.40	0.4 0.50	0.28 0.22	0.2 0.09									
3.6	60	1.00	3.06 43.0	1.85 15.0	1.2 6.5	0.76 1.90	0.48 0.70	0.34 0.32	0.24 0.13	0.16 0.050								
4.2	70	1.12	3.43 50.0	2.08 18.0	1.34 8.0	0.86 2.50	0.54 0.83	0.38 0.38	0.26 0.17	0.18 0.068								
4.8	80	1.33	2.47 25.0	1.59 10.5	1.02 3.00	0.64 1.20	0.45 0.50	0.31 0.22	0.2 0.084									
5.4	90	1.50	2.78 30.0	1.8 12.0	1.15 3.50	0.72 1.30	0.51 0.57	0.35 0.26	0.24 0.092	0.18 0.05								
6.0	100	1.67	3.1 39.0	2.0 16.0	1.28 4.6	0.8 1.80	0.56 0.73	0.39 0.30	0.26 0.12	0.2 0.07								
7.5	125	2.08	3.86 50.0	2.49 24.0	1.59 6.6	1.00 2.50	0.70 1.10	0.49 0.50	0.33 0.18	0.25 0.10	0.20 0.055							
9.0	150	2.50			3.00 33.0	1.91 8.6	1.20 3.5	0.84 1.40	0.59 0.63	0.39 0.24	0.30 0.13	0.24 0.075						
10.5	175	2.92			3.5 38.0	2.23 11.0	1.41 4.3	0.99 1.80	0.69 0.78	0.46 0.30	0.36 0.18	0.28 0.09						
12	200	3.33			3.99 50.0	2.55 14.0	1.60 5.5	1.12 2.40	0.78 1.0	0.52 0.40	0.41 0.22	0.32 0.12	0.25 0.065					
15	250	4.17				3.19 21.0	2.01 8.0	1.41 3.70	0.98 1.50	0.66 0.57	0.51 0.34	0.40 0.18	0.31 0.105	0.25 0.06				
18	300	5.00				3.82 28.0	2.41 10.5	1.69 4.60	1.18 1.95	0.78 0.77	0.61 0.45	0.48 0.25	0.37 0.13	0.29 0.085				
24	400	6.67					3.21 19.0	2.25 8.0	1.57 3.60	1.05 1.40	0.81 0.78	0.65 0.44	0.50 0.23	0.39 0.15				
30	500	8.33					4.01 28.0	2.81 11.5	1.96 5.0	1.31 2.0	1.02 0.63	0.81 0.33	0.62 0.21	0.49 0.21				
36	600	10.0					4.82 37.0	3.38 15.0	2.35 6.6	1.57 2.60	1.22 1.50	0.97 0.82	0.74 0.45	0.59 0.28				
42	700	11.7					5.64 47.0	3.95 24.0	2.75 8.0	1.84 3.50	1.43 1.90	1.13 1.10	0.87 0.60	0.69 0.40				
48	800	13.3						4.49 26.0	3.13 11.0	2.09 4.5	1.62 2.60	1.29 1.40	0.99 0.81	0.78 0.48				
54	900	15.0						5.07 33.0	3.53 13.5	2.36 5.5	1.83 3.20	1.45 1.70	1.12 0.95	0.08 0.58				
60	1000	16.7						5.64 40.0	3.93 16.0	2.63 6.7	2.04 3.90	1.62 2.2	1.24 1.2	0.96 0.75				
75	1250	20.8							4.89 25.0	3.27 9.0	2.54 5.0	2.02 3.0	1.55 1.6	1.22 0.95				
90	1500	25.0							5.88 33.0	3.93 13.0	3.05 8.0	2.42 4.1	1.86 2.3	1.47 1.40				
105	1750	29.2							6.86 44.0	4.59 17.5	3.56 9.7	2.83 5.7	2.17 3.2	1.72 1.9				
120	2000	33.3								5.23 23.0	4.06 13.0	3.23 7.0	2.48 4.0	1.96 2.4				
150	2500	41.7								6.55 34.0	5.08 18.0	4.04 10.5	3.10 6.0	2.45 3.5				
180	3000	50.0								7.86 45.0	6.1 27.0	4.85 14.0	3.72 7.6	2.94 4.4				
240	4000	66.7									8.13 43.0	6.47 24.0	4.96 13.0	3.92 7.5				
300	5000	83.3										8.08 33.0	6.2 18.0	4.89 11.0				

The table is based on a nomogram.

Roughness: K = 0.01 mm.

Water temperature: t = 10°C.

Product numbers

The pump is supplied complete with motor and cable guard fitted, but without the cable with plug, which must be ordered separately.

SP 3A-NE, 1 x 230 V

Pump type	Motor		Product number
	Type	P ₂ [kW]	
SP 3A-6 NE	MS 4000 RE	2.2	10222106
SP 3A-9 NE	MS 4000 RE	2.2	10222109
SP 3A-12 NE	MS 4000 RE	2.2	10222112
SP 3A-15 NE	MS 4000 RE	2.2	10222115
SP 3A-18 NE	MS 4000 RE	2.2	10222118
SP 3A-22 NE	MS 4000 RE	2.2	10222122
SP 3A-25 NE	MS 4000 RE	2.2	10222125
SP 3A-29 NE	MS 4000 RE	2.2	10222129

SP 5A-NE, 1 x 230 V

Pump type	Motor		Product number
	Type	P ₂ [kW]	
SP 5A-4 NE	MS 4000 RE	2.2	05222104
SP 5A-6 NE	MS 4000 RE	2.2	05222106
SP 5A-8 NE	MS 4000 RE	2.2	05222108
SP 5A-12 NE	MS 4000 RE	2.2	05222112
SP 5A-17 NE	MS 4000 RE	2.2	05222117
SP 5A-21 NE	MS 4000 RE	2.2	05222121
SP 5A-25 NE	MS 4000 RE	2.2	05222125
SP 5A-33 NE	MS 4000 RE	2.2	05222133

SP 8A-NE, 1 x 230 V

Pump type	Motor		Product number
	Type	P ₂ [kW]	
SP 8A-5 NE	MS 4000 RE	2.2	11222105
SP 8A-7 NE	MS 4000 RE	2.2	11222107
SP 8A-10 NE	MS 4000 RE	2.2	11222110
SP 8A-12 NE	MS 4000 RE	2.2	11222112
SP 8A-15 NE	MS 4000 RE	2.2	11222115

SP 17-NE, 1 x 230 V

Pump type	Motor		Product number
	Type	P ₂ [kW]	
SP 17-1 NE	MS 4000 RE	2.2	12C92101
SP 17-2 NE	MS 4000 RE	2.2	12C92102
SP 17-3 NE	MS 4000 RE	2.2	12C92103
SP 17-4 NE	MS 4000 RE	2.2	12C92104

Cables

Motor cables complete with one motor plug.

Cable length [m]	Product number
10	00795667
20	00795668
30	00795669
40	00795670
50	00795671
60	00795672
70	00795673
80	00795674
90	00795675
100	00795676
120	96426909

SP 3A-NE, 3 x 400 V

Pump type	Motor		Product number
	Type	P ₂ [kW]	
SP 3A-6 NE	MS 4000 RE	0.75	10221906
SP 3A-9 NE	MS 4000 RE	0.75	10221909
SP 3A-12 NE	MS 4000 RE	0.75	10221912
SP 3A-15 NE	MS 4000 RE	1.1	10221915
SP 3A-18 NE	MS 4000 RE	1.1	10221918
SP 3A-22 NE	MS 4000 RE	1.5	10221922
SP 3A-25 NE	MS 4000 RE	1.5	10221925
SP 3A-29 NE	MS 4000 RE	2.2	10221929

SP 5A-NE, 3 x 400 V

Pump type	Motor		Product number
	Type	P ₂ [kW]	
SP 5A-4 NE	MS 4000 RE	0.75	05221904
SP 5A-6 NE	MS 4000 RE	0.75	05221906
SP 5A-8 NE	MS 4000 RE	0.75	05221908
SP 5A-12 NE	MS 4000 RE	1.1	05221912
SP 5A-17 NE	MS 4000 RE	1.5	05221917
SP 5A-21 NE	MS 4000 RE	2.2	05221921
SP 5A-25 NE	MS 4000 RE	2.2	05221925
SP 5A-33 NE	MS 4000 RE	3.0	05221933

SP 8A-NE, 3 x 400 V

Pump type	Motor		Product number
	Type	P ₂ [kW]	
SP 8A-5 NE	MS 4000 RE	0.75	11221905
SP 8A-7 NE	MS 4000 RE	1.1	11221907
SP 8A-10 NE	MS 4000 RE	1.5	11221910
SP 8A-12 NE	MS 4000 RE	2.2	11221912
SP 8A-15 NE	MS 4000 RE	2.2	11221915
SP 8A-18 NE	MS 4000 RE	3.0	11221918
SP 8A-21 NE	MS 4000 RE	4.0	11221921
SP 8A-25 NE	MS 4000 RE	4.0	11221925

SP 17-NE, 3 x 400 V

Pump type	Motor		Product number
	Type	P ₂ [kW]	
SP 17-1 NE	MS 4000 RE	0.75	12C91901
SP 17-2 NE	MS 4000 RE	1.1	12C91902
SP 17-3 NE	MS 4000 RE	2.2	12C91903
SP 17-4 NE	MS 4000 RE	2.2	12C91904
SP 17-5 NE	MS 4000 RE	3.0	12C91905
SP 17-6 NE	MS 4000 RE	4.0	12C91906
SP 17-7 NE	MS 4000 RE	4.0	12C91907
SP 17-8 NE	MS 4000 RE	5.5	12C91908
SP 17-9 NE	MS 4000 RE	5.5	12C91909
SP 17-10 NE	MS 4000 RE	5.5	12C91910

Resistance list

A number of typical liquids are listed below.
The list is to be used as a guide only.

Legend

- = Not applicable.

Pure saturated acids, not specified

	Liquid	Chemical formula	Concentration	Max. liquid temperature		
				SP(A)-NE	SQE-NE	MP 1
Acids	Acetic acid	CH ₃ COOH	15%	30°C	30°C	-
	Benzoic acid	C ₆ H ₅ COOH	100%	20°C	20°C	20°C
	Boric acid	H ₃ BO ₃	30%	40°C	40°C	40°C
	Chromic acid	H ₂ CrO ₄	20%	20°C	-	-
	Citric acid	HOC(CH ₂ CO ₂ H) ₂ COOH	40%	40°C	40°C	40°C
	Formic acid	HCOOH	100%	20°C	-	20°C
	Hydrochloric acid	HCl	10%	-	-	-
	Hydrogen Fluoride	HF	1%	20°C	20°C	20°C
	Lactic acid	CH ₃ CH(OH)COOH	100%	20°C	-	20°C
	Linoleic acid	C ₁₇ H ₃₁ COOH	100%	20°C	-	20°C
	Nitric acid	HNO ₃	10%	-	-	-
	Oxalic acid	(COOH) ₂	15%	40°C	40°C	40°C
	Phosphoric acid	H ₃ PO ₄	30%	20°C	20°C	20°C
	Salicylic acid	C ₆ H ₄ (OH)COOH	40%	0°C	40°C	40°C
	Sulfuric acid	H ₂ SO ₄	5%	20°C	10°C	20°C

Neutral liquids

	Liquid	Chemical formula	Concentration	Max. liquid temperature		
				SP(A)-NE	SQE-NE	MP 1
De-ionized water	-	H ₂ O	-	40°C	40°C	40°C

Alkaline liquids

	Liquid	Chemical formula	Concentration	Max. liquid temperature		
				SP(A)-NE	SQE-NE	MP 1
Alkalis	Ammonia	NH ₃	25%	-	-	-
	Ammonium hydroxide	NH ₄ OH	60%	20°C	-	-
	Barium hydroxide	Ba(OH) ₂	10%	40°C	40°C	40°C
	Calcium hydroxide	Ca(OH) ₂	10%	20°C	-	20°C
	Calcium hypochlorite	Ca(ClO) ₂	10%	-	-	-
	Potassium hydroxide	KOH	1%	-	-	-
	Sodium hydroxide	NaOH	1%	20°C	20°C	20°C
	Sodium hypochlorite	NaOCl	10%	-	-	-

Salts in aqueous solutions

	Liquid	Chemical formula	Concentration	Max. liquid temperature		
				SP(A)-NE	SQE-NE	MP 1
Acetate	Sodium acetate	CH ₃ COONa	1%	20°C	20°C	20°C
Borate	Sodium tetra borate	Na ₂ B ₄ O ₇	1%	40°C	40°C	40°C
Bromate	Bromate	BrO ₃ ⁻	1%	40°C	40°C	40°C
Carbonates	Carbonates	CO ₃ ²⁻	1%	40°C	40°C	40°C
	Potassium bicarbonate	KHCO ₃	10%	40°C	40°C	40°C
	Potassium carbonate	K ₂ CO ₃	20%	40°C	40°C	40°C
	Sodium carbonate	Na ₂ CO ₃	20%	40°C	40°C	40°C
	Sodium hydrogencarbonate	NaHCO ₃	10%	40°C	40°C	40°C
Chlorates	Sodium chlorate	NaClO ₃	20%	20°C	-	-
	Sodium perchlorate	NaClO ₄	30%	40°C	-	-
Chlorides	Aluminium chloride	AlCl ₃	0.1%	-	-	-
	Ferric chloride	FeCl ₃	0.1%	-	-	-
	Ferrous chloride	FeCl ₂	1%	20°C	20°C	20°C
	Sodium chloride	NaCl	1000ppm (0.1%)	20°C	20°C	20°C
Chromates	Chromates	CrO ₄ ²⁻	1%	40°C	40°C	40°C
	Potassium dichromate	K ₂ Cr ₂ O ₇	20%	20°C	-	-
Hypochlorite	Hypochlorite	ClO ⁻	<0.1%	20°C	-	-
Iodide	Iodides	I ⁻	<0.5%	20°C	20°C	20°C
Nitrates	Ammonium nitrate	NH ₄ NO ₃	20%	40°C	40°C	40°C
	Barium nitrate	Ba(NO ₃) ₂	10%	40°C	40°C	40°C
	Nitrate	NO ₃ ⁻	1%	40°C	40°C	40°C
	Silver nitrate	AgNO ₃	20%	40°C	40°C	40°C
	Sodium nitrate	NaNO ₃	20%	40°C	0°C	40°C
Nitrites	Nitrite	NO ₂ ⁻	1%	40°C	40°C	40°C
	Sodium nitrite	NaNO ₂	20%	40°C	40°C	40°C
Peroxides	Peroxides	O ₂ ²⁻	10%	20°C	-	-
	Potassium permanganate	KMnO ₄	10%	40°C	20°C	-
Phosphate	Sodium phosphate	Na ₃ PO ₄	1%	40°C	40°C	40°C
Silicate	Sodium metasilicate	Na ₂ SiO ₃	10%	40°C	40°C	40°C
Sulfates	Ammonium sulfate	(NH ₄) ₂ SO ₄	20%	40°C	40°C	40°C
	Copper sulfate	CuSO ₄	20%	40°C	40°C	40°C
	Ferric sulfate	Fe ₂ (SO ₄) ₃	10%	40°C	40°C	40°C
	Ferrous sulfate	FeSO ₄	10%	40°C	40°C	40°C
	Magnesium sulfate	MgSO ₄	20%	40°C	40°C	40°C
	Sodium hydrogen sulfate	NaHSO ₄	10%	20°C	40°C	20°C
	Sodium sulfate	Na ₂ SO ₄	10%	20°C	40°C	20°C
	Sulfate	SO ₄ ²⁻	1%	40°C	40°C	40°C
Sulfites	Sodium hydrogen sulfite	NaHSO ₃	10%	20°C	20°C	20°C
	Sodium sulfite	Na ₂ SO ₃	20%	20°C	20°C	20°C
	Sulfite	SO ₃ ²⁻	1%	40°C	40°C	40°C

Gasses, saturated solutions

	Liquid	Chemical formula	Concentration	Max. liquid temperature		
				SP(A)-NE	SQE-NE	MP 1
Gasses	Bromine	Br ₂	5ppm	-	-	-
	Carbon dioxide	CO ₂	5ppm	40°C	40°C	40°C
	Chlorine	Cl ₂	5ppm	40°C	40°C	40°C
	Hydrogen sulfide	H ₂ S	5ppm	-	-	-
	Iodine	I ₂	5ppm	-	-	-
	Ozone	O ₃	5ppm	40°C	40°C	-
	Sulfur dioxide	SO ₂	5ppm	40°C	40°C	40°C

Organic liquids

Homopolar liquids, oils

	Liquid	Chemical formula	Concentration	Max. liquid temperature		
				SP(A)-NE	SQE-NE	MP 1
Mineral oils	ASTM1		100%	40°C	40°C	40°C
	ASTM3		100%	40°C	40°C	40°C
Silicone	Silicone oil		100%	40°C	40°C	40°C
Vegetable/animal oils	Corn oil		100%	20°C	20°C	20°C
	Olive oil		100%	20°C	20°C	20°C
	Peanut oil		100%	-	-	-
	Rape seed oil		100%	20°C	20°C	20°C
	Soya bean oil		100%	20°C	20°C	20°C

Organic liquids

Homopolar liquids, solutions/fuels

	Liquid	Chemical formula	Concentration	Max. liquid temperature		
				SP(A)-NE	SQE-NE	MP 1
Alicyclic organic liquids	Cyclohexane	C ₆ H ₁₂	1%	40°C	40°C	40°C
	Naphtalene	C ₁₀ H ₈	1%	-	-	-
Aliphatic	Hexane	C ₆ H ₁₄	1%	40°C	40°C	40°C
	Octane	C ₈ H ₁₈	1%	40°C	40°C	40°C
	Pentane	C ₅ H ₁₂	1%	40°C	40°C	40°C
Compounds	Diesel oil		1%	40°C	40°C	40°C
	Jet fuel		1%	-	-	-
	Motor oil		1%	20°C	20°C	20°C
	Paraffin oil		1%	20°C	20°C	20°C
	Petroleum		1%	40°C	40°C	40°C
	Tar oil		1%	-	-	-
	Turpentine		1%	40°C	40°C	40°C

Organic liquids

Homopolar liquids, solutions/fuels

	Liquid	Chemical formula	Concentration	Max. liquid temperature		
				SP(A)-NE	SQE-NE	MP 1
Aromatic organic liquids	Benzene	C ₆ H ₆	1%	-	-	-
	Diphenyl	C ₆ H ₅ C ₆ H ₅	1%	25°C	25°C	25°C
	Toluene	C ₆ H ₅ CH ₃	1%	40°C	40°C	-
	Xylene	C ₆ H ₄ (CH ₃) ₂	1%	40°C	40°C	-

Organic liquids

Polar liquids, chlorine-containing

	Liquid	Chemical formula	Concentration	Max. liquid temperature		
				SP(A)-NE	SQE-NE	MP 1
Polar solutions	Chloroform	CHCl ₃	1%	40°C	25°C	25°C
	Methylene chloride	CH ₂ Cl ₂	1%	-	-	-
	Perchloroethylene	C ₂ Cl ₄	1%	40°C	25°C	25°C
	Tetrachloroethane	C ₂ H ₂ Cl ₄	25%	-	-	-
	Tetrachloroethylene	C ₂ Cl ₄	25%	-	-	-
	Trichlorethylene	C ₂ HCl ₃	25%	25°C	-	25°C

Organic liquids

Polar liquids, oxygenous

	Liquid	Chemical formula	Concentration	Max. liquid temperature		
				SP(A)-NE	SQE-NE	MP 1
Acids, low molecular	Acetic acid	CH ₃ COOH	100%	-	-	-
	Formic acid	HCOOH	100%	-	-	-
Alcohols	Butanol (butyl alcohol)	C ₄ H ₉ OH	100%	40°C	40°C	40°C
	Ethanol (ethyl alcohol)	C ₂ H ₅ OH	100%	-	-	-
	Methanol (methyl alcohol)	CH ₃ OH	100%	-	-	-
	Phenol	C ₆ H ₅ OH	100%	-	-	-
	Propanol	C ₃ H ₇ OH	100%	20°C	20°C	20°C
Aldehydes	Benzaldehyde	C ₆ H ₅ CHO	100%	-	-	-
	Formalin (formaldehyde)	CH ₂ O	30%	-	-	-
Cyclic ether	Dioxan	C ₄ H ₈ O ₂	100%	-	-	-
Esters	Ethyl acetate	CH ₃ COOC ₂ H ₅	100%	-	-	-
	Isobutyl acetate	C ₆ H ₁₂ O ₂	100%	-	-	-
Ethers	Cellosolve	C ₂ H ₅ OCH ₂ CH ₂ OH	100%	-	-	-
	Diethyl ether	C ₂ H ₅ OC ₂ H ₅	100%	-	-	-
	Methyl ethyl ether	C ₃ H ₈ O	100%	-	-	-
Glycols	Ethylene glycol	HOCH ₂ CH ₂ OH	100%	40°C	25°C	40°C
	Glycerine (glycerol)	OHCH ₂ CH(OH)CH ₂ OH	100%	40°C	40°C	40°C
	Propylene glycol	CH ₃ CH(OH)CH ₂ OH	100%	20°C	20°C	20°C
Ketones	Acetone	CH ₃ COCH ₃	100%	-	-	-
	Acetophenone	C ₆ H ₅ COCH ₃	100%	-	-	-
	Cyclohexanone	C ₆ H ₁₀ O	100%	-	-	-
	MEK (methyl ethyl ketone)	C ₄ H ₈ O	100%	-	-	-
	MIBK (methyl isobutyl ketone)	C ₆ H ₁₂ O	100%	-	-	-

Organic liquids

Polar liquids, P-containing

	Liquid	Chemical formula	Concentration	Max. liquid temperature		
				SP(A)-NE	SQE-NE	MP 1
Phosphate ester	Skydrol 500		100%	-	-	-
	Skydrol 7000		100%	-	-	-
	Tributyl phosphate	(C ₄ H ₉) ₃ PO ₄	100%	-	-	-

Polar liquids, N-containing

	Liquid	Chemical formula	Concentration	Max. liquid temperature		
				SP(A)-NE	SQE-NE	MP 1
Additives for cooling lubricating liquids	NACE A (water)			-	-	-
	NACE B (oil)			-	-	-
Amides	Acetamide	C ₂ H ₅ NO	100%	-	-	-
	Formamide	CH ₃ NO	100%	-	-	-
Amines	Aniline	C ₆ H ₅ NH ₂	100%	40°C	20°C	40°C
	Dimethylamine	(CH ₃) ₂ NH	100%	-	-	-
	Ethylamine	C ₂ H ₅ NH ₂	100%	-	-	-
	Hydrazine	H ₂ NNH ₂	100%	-	-	-
	Tert-butylamine	(CH ₃) ₃ CNH ₂	100%	-	-	-
	Triethanolamine	(HOC ₂ H ₄) ₃ N	100%	-	-	-
Cyclic organic liquid	Pyridine	C ₅ H ₅ N	100%	-	-	-

Polar liquids, S-containing

	Liquid	Chemical formula	Concentration	Max. liquid temperature		
				SP(A)-NE	SQE-NE	MP 1
Certain S-containing additives	Corrosion inhibitors			-	-	-
EP additives	Friction improving bodies			-	-	-

Aqueous solutions

	Liquid	Chemical formula	Concentration	Max. liquid temperature		
				SP(A)-NE	SQE-NE	MP 1
Acetates	Copper acetate	$(\text{CH}_3\text{COO})_2\text{Cu}$	100%	-	-	-
	Sodium acetate	CH_3COONa	100%	-	-	-
Acids	Ascorbic acid	$\text{C}_6\text{H}_8\text{O}_6$	100%	40°C	40°C	40°C
	Benzoic acid	$\text{C}_6\text{H}_5\text{COOH}$	100%	40°C	20°C	40°C
	Citric acid	$\text{C}_6\text{H}_8\text{O}_7$	40%	40°C	40°C	40°C
Formates	Sodium formate	HCOONa	100%	-	-	-
Glycols	Glycol-based brake fluids			-	-	-
Salts of organic amines	Tetramethylammonium chloride	$\text{C}_4\text{H}_{12}\text{ClN}$	100%	-	-	-

V7121578 0205	GB
Repl. V7 12 15 78 10 03	

Subject to alterations.